



# Guidance for implementation of electric vehicle charging infrastructure

First edition  
April 2010



Transport  
for London

# CONTENTS

1. Introduction
  - 1.1 Who should use this guide?
  - 1.2 What is the guide for?
  - 1.3 Why is the guide needed?
  - 1.4 London-wide policy context
  - 1.5 Implementation stages
2. Overview of charging infrastructure
  - 2.1 Introduction
  - 2.2 Charging point types/locations
  - 2.3 Components of charging point system
  - 2.4 Electricity supply
  - 2.5 Charging point operation
  - 2.6 Electric vehicle charging
3. Costs, funding and procurement
  - 3.1 Introduction
  - 3.2 Typical costs
  - 3.3 Funding opportunities
  - 3.4 Procurement
4. Location and design considerations
  - 4.1 Introduction
  - 4.2 Location of charging points
  - 4.3 Planning legislation
  - 4.4 Parking controls
  - 4.5 Typical layout details
  - 4.6 Impact on streetscape
  - 4.7 Consultation
  - 4.8 Enforcement
  - 4.9 Charging point suppliers and energy distributor
  - 4.10 Timescales
5. Installation and maintenance
  - 5.1 Introduction
  - 5.2 Installation
  - 5.3 Maintenance
6. Marketing, branding and publicity
  - 6.1 Introduction
  - 6.2 Marketing
  - 6.3 Branding and publicity
7. Administration
  - 7.1 Introduction
  - 7.2 Application process
  - 7.3 Network administrator support
  - 7.4 Future administration of pan-London network

Appendix A – Design checklist

Appendix B – Service Level Agreement pro-forma

Appendix C – References

Appendix D – Important contacts

Appendix E – EVCP Partnership Working Group

Appendix F – Glossary

# Chapter 1 – Introduction

# 1. Introduction

- 1.1 Who should use this guide?
- 1.2 What is the guide for?
- 1.3 Why is the guide needed?
- 1.4 London-wide policy context
- 1.5 Implementation stages

## 1.1 Who should use this guide?

- 1.1.1 This guide is aimed primarily at borough officers who are responsible for the procurement, design, installation and operation of electric vehicle charging points (EVCPs) on public highways and in public car parks.
- 1.1.2 However, given that the document provides information on all aspects of the EVCP implementation process, it is likely that it will be useful for a host of other organisations and stakeholders, including:

- Suppliers of EVCP technology
- Energy distributors and energy suppliers
- Employers (installing EVCPs in car parks)
- Developers (introducing EVCPs in new developments)
- Local and regional government authorities outside London
- Car Club operators
- Producers of electric vehicles
- Transport planners



## 1.2 What is the guide for?

- 1.2.1 The intention of this document is to provide a step-by-step guide to borough council officers who are considering implementing EVCPs within their borough, whether on-street or off-street in public car parks. Specifically, the guide aims to simplify and make more accessible the process of EVCP provision. Unless otherwise stated, the information in this guide will relate to both on-street and off-street installations.
- 1.2.2 The document is structured such that it guides the reader through the entire process, from needs-based considerations, to procurement, design, installation and operation. Each chapter addresses some of the typical questions the reader may have and provides transparency and clarity as to which parties are responsible for which elements of the implementation process.

## 1.3 Why is the guide needed?

- 1.3.1 Electric vehicles (EVs) have been in existence for more than a century but it is only more recently that the environmental benefits of this technology have been acknowledged. The

Mayor of London aims to achieve a significant increase in the number of electric vehicles in the Capital and to support this will require the introduction of a comprehensive network of EVCPs.

“ The uptake of EVs in London is a Mayoral priority, not only for environmental reasons, but also for the associated economic and job creation opportunities. ”

*(Mayor's draft Transport Strategy, October 09)*

1.3.2 There are currently more than 200 plug-in charging locations in London, distributed across 13 boroughs and the City of London in car parks, shopping and leisure centres and on-street locations. The London Borough of Westminster currently hosts more than 70 charging points across the borough. Details on the location of current charging points and information on electric vehicles can be found on the Newride website<sup>1</sup>, which is hosted by the Clear Zones Partnership.

1.3.3 However, the technology is in its infancy and it is often difficult to establish who is responsible for what and where to find the answers to questions regarding, for example, where charging point bays should be located. In addition, there are aspirations to provide a greater level of consistency in the processes that are followed in introducing and operating charging points.



*Source: Electric Vehicle Delivery Plan for London*

1.3.4 Transport for London (TfL) has produced this guide in response to the challenges faced by borough officers installing EVCPs. It will be updated on a regular basis to reflect changes in technology and processes.

1.3.5 This guide has been developed with the assistance of several London boroughs, London Councils, electric vehicle charging point suppliers and the energy distributor for London.

1.3.6 Further information on electric vehicle charging points and related programmes and publications is available on the TfL extranet (<http://boroughs.tfl.gov.uk/1054.aspx>).

## 1.4 London-wide policy context

1.4.1 Climate change is the biggest threat to the future development of human civilisation and poses a huge challenge for cities such as London. The Mayor of London has a legal obligation to have regard to climate change and to take action to address both the causes and its consequences. The Mayor of London has set a target to reduce London's greenhouse gas emissions by 60 per cent from their 1990 levels by 2025.



*Source: Electric Vehicle Delivery Plan for London*

1.4.2 The UK is the world's eighth largest emitter of CO<sub>2</sub>. London is responsible for 8 per cent of these emissions,

<sup>1</sup> Newride website – [www.newride.org.uk](http://www.newride.org.uk)

producing 44m tonnes of CO<sub>2</sub> each year. Transport accounts for 22 per cent of CO<sub>2</sub> emissions in London and road-based modes comprise 81 per cent of this total. There is growing agreement that electric vehicle technology is the most 'near to market' green technology with the potential for uptake in the short to medium term. 'Well to wheel' carbon dioxide emissions from electric vehicles are up to 40 per cent lower than comparable petrol or diesel-fuelled vehicles.

- 1.4.3 London currently has some of the worst air pollution in the UK, with significant health implications for Londoners. Parts of London are not meeting EU targets for the most harmful pollutants, nitrogen dioxide (NO<sub>2</sub>) and fine particulate matter (PM<sub>10</sub>). Forty-six per cent of Greater London's emissions of NO<sub>x</sub> (NO and NO<sub>2</sub>) and 83 per cent of central London PM<sub>10</sub> emissions come from road transport. As EVs do not emit any pollutants at the point of use they are an important step in tackling poor air quality in London.
- 1.4.4 There are currently 1,700 EV users registered for the Congestion Charging 100 per cent discount in London, although the total number of EV users in the Capital is likely to be higher. The Mayor of London wants to boost the number of EV users in London to 100,000 (or 5 per cent of the Capital's fleet) as soon as possible. The potential for electric vehicle use in London is high given that: journeys are often shorter<sup>2</sup>; there is a 100 per cent discount on the Congestion Charge and many boroughs offer concessions on parking for electric vehicles.
- 1.4.5 Other incentives that benefit electric vehicle drivers include: lower fuel costs, exemption from first-year rate and annual vehicle tax; discounted insurance premiums offered by some insurers and exemption from company car tax for five years from April 2010.

**Benefits to users of electric vehicles in London:**

- trips are shorter, therefore range is less of an issue
- 100 per cent discount on congestion charge
- parking concessions offered by some boroughs
- lower fuel costs
- exemption from annual vehicle tax
- discounted insurance premiums
- reduced company car tax

- 1.4.6 In addition, the Department for Transport (DfT) has allocated £250m for an incentive scheme to increase the uptake of electric and plug-in hybrid vehicles. This includes £20m earmarked for a charging infrastructure framework programme (called 'Plugged in Places') supplemented by up to £10m from the low carbon element of the Strategic Investment Fund. The £230m consumer incentives aim to reduce the price of EVs and plug-in hybrid vehicles to consumers from 2011 onwards.
- 1.4.7 The current lack of charging infrastructure acts as a major barrier to the greater use of electric vehicles. The measures that are being taken to address this issue are identified in the Mayor's *Electric Vehicle Delivery Plan for London*, published in May 2009, and in the draft *London's Electric Vehicle Infrastructure Strategy*<sup>3</sup>.

---

<sup>2</sup> *An Electric Vehicle Delivery Plan for London*

<sup>3</sup> Consultation draft, December 2009: *London's Electric Vehicle Infrastructure Strategy*

1.4.8 In addition to setting out actions relating to incentives, marketing and communication and the expansion of the public sector electric vehicle fleet, the Delivery Plan sets a target for the provision of 25,000 charging points by 2015, including 500 on-street charging points and 2,000 charging points in off-street public car parks and Tube/Overground rail station car parks. The remaining 22,500 charging points will be provided in workplace car parks.

**“ Londoners embrace new technology – London contains the largest fleet of electric and hybrid vehicles in the UK ”**

*(Electric Vehicle Delivery Plan for London, May 2009)*

1.4.9 The revisions to the London Plan include a condition that requires between 10-20 per cent of parking spaces for new development to be provided with charging point infrastructure. Further information on the Mayor of London's targets and electric vehicles in general are available on the Greater London Authority (GLA) EV website<sup>4</sup>.

1.4.10 It is expected that the majority of users will charge their vehicles off-street at home. It is likely that utility companies will begin to offer competitive packages to EV owners, which could include the cost of the charging equipment and a subsidy towards the cost of installation.

1.4.11 *London's EV Infrastructure Strategy* describes how the charging infrastructure will evolve over the next 15 years and provides details on the factors that will influence the type and location of charging points. The Strategy also sets out the proposals for the pan-London charging network, which aims to introduce a greater level of consistency in the processes that are followed in introducing and operating charging points. The introduction of the pan-London scheme is being targeted for late 2010.

**Mayor of London's Plans for EVCP network:**

- **Deliver 25,000 charge points by 2015, including:**
- **500 on-street points and 2,000 off-street points in public car parks and station car parks**
- **22,500 in employer's car parks**

---

<sup>4</sup> GLA EV website - [www.london.gov.uk/electricvehicles/](http://www.london.gov.uk/electricvehicles/)

## 1.5 Implementation stages

1.5.1 The process for introducing charging points is shown in Figure 1.1, together with the parties that are responsible for each of the stages.

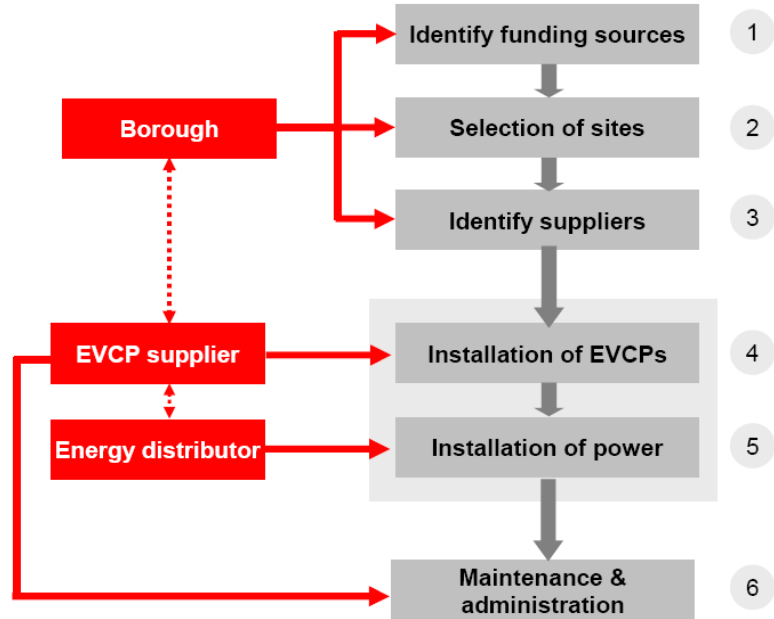

Figure 1.1 – Implementation stages

## Chapter 2 – Overview of charging infrastructure

## 2. Overview of charging infrastructure

- 2.1 Introduction
- 2.2 Charging point types/locations
- 2.3 Components of charging point system
- 2.4 Electricity supply
- 2.5 Charging point operation
- 2.6 Electric vehicle charging

### 2.1 Introduction

2.1.1 This chapter provides an introduction to the different types of charging points, where they are usually located and how they work. The terminology is explained in simple terms and for ease of reference is also summarised in Appendix E – Glossary.

2.1.2 Charging point technology is in its infancy and is evolving quickly. As the London charging network expands over the next few years, it is likely that advancements will be made to charging point equipment and in the operation of the network. In this guide, we reflect some of the aspirations for how the network may operate in the future and some of the technological changes that are likely to happen. However, the guide focuses on the technology and systems that are currently in use in London.



Source: Infracharge Ltd

### 2.2 Charging point types/locations

2.2.1 Electric vehicles can be charged on-street or off-street using different types of charging points as summarised in Table 2.1 and as shown in Figure 2.1.

**Table 2.1** – Charging point types/locations

Type	On-street/ off-street	Public/ private	Locations	Shared	Restricted access (RA) / Open access (OA)	Plug type
A	On-street	Public	All (high streets, residential areas etc)	Yes	RA	3-pin
B	Off-street	Public	Car parks – leisure & retail centres, community facilities, stations, parks	Yes	RA/OA	3-pin/blue commando
C	Off-street	Private	Car parks – workplaces, residential apartments	Yes	RA/OA	3-pin/blue commando
D	Off-street	Private	Residential	No	OA	3-pin/blue commando

Terminology for charging point types/locations:	
Public	– for use by the general public. On-street or off-street in municipal or other publicly accessible car parks (eg supermarkets)
Restricted access (RA)	– use of charging points restricted to subscribers
Open access (OA)	– for use by any EV owners (ie includes non-subscribers)
Shared	– for open access, for use by subscribers (to a borough’s network) or for shared use in workplaces or residential developments

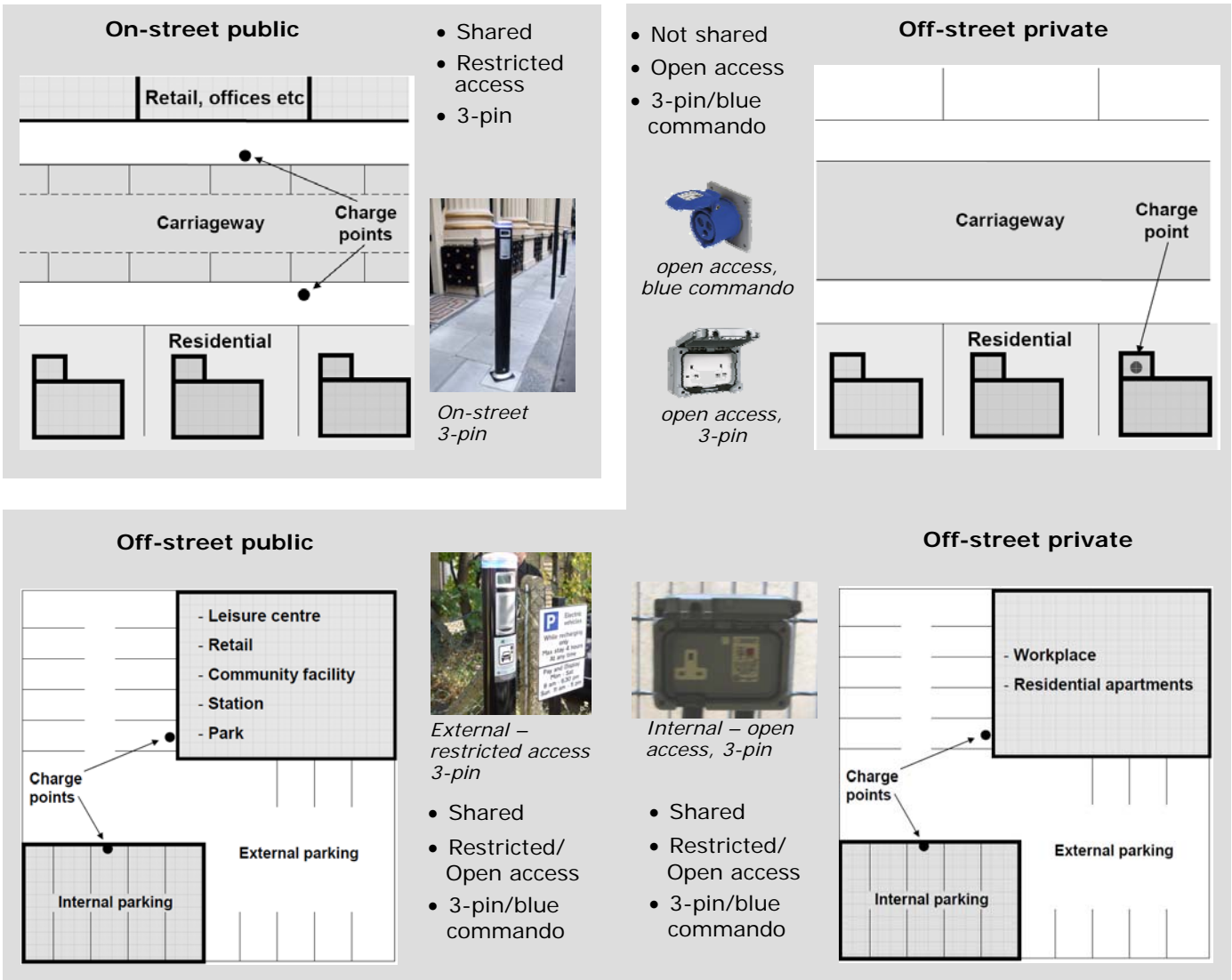

Figure 2.1 - Charging point types and locations

2.2.2 On-street charging points are floor (footway) mounted and off-street charging points in external car parks (usually surface level) can be floor mounted or wall mounted. The charging points in internal car parks (generally multi-storey) are wall mounted as often the ground surface cannot be disturbed or there is limited depth to install foundations for surface mounted points.



**On-street RA floor mounted**



**Off-street RA (external) floor mounted**



**Off-street RA (external) wall mounted**



**Off-street RA (internal) wall mounted**



**Off-street OA (internal) wall mounted**

**TfL plans for installing EVCPs on the TLRN:**

TfL is investigating installing charging points on the Transport for London Road Network (TLRN) and a shortlist of locations has been identified. For integration and consistency, TfL will inform the relevant boroughs of the proposed locations.

**2.3 Components of charging point system**

2.3.1 The main components of a charging point system are shown in Figure 2.2 and Figure 2.3. These can be described as physical components but there are also operational components such as the administration system. The operational aspects are discussed in Chapter 7.

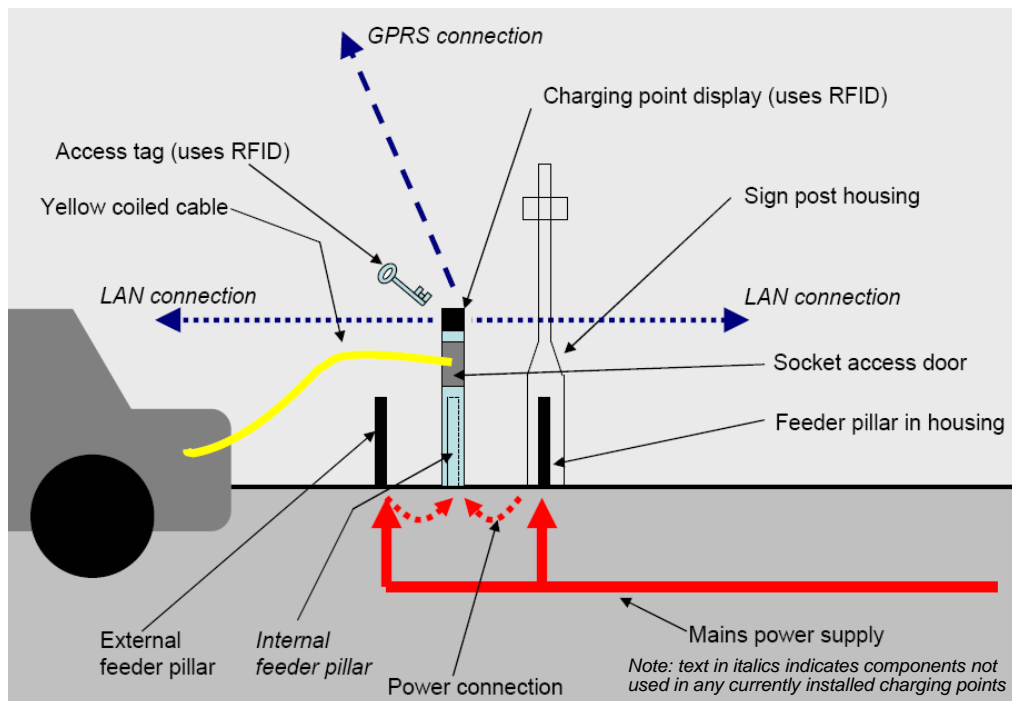

**Figure 2.2 – components of on-street restricted access charging points**

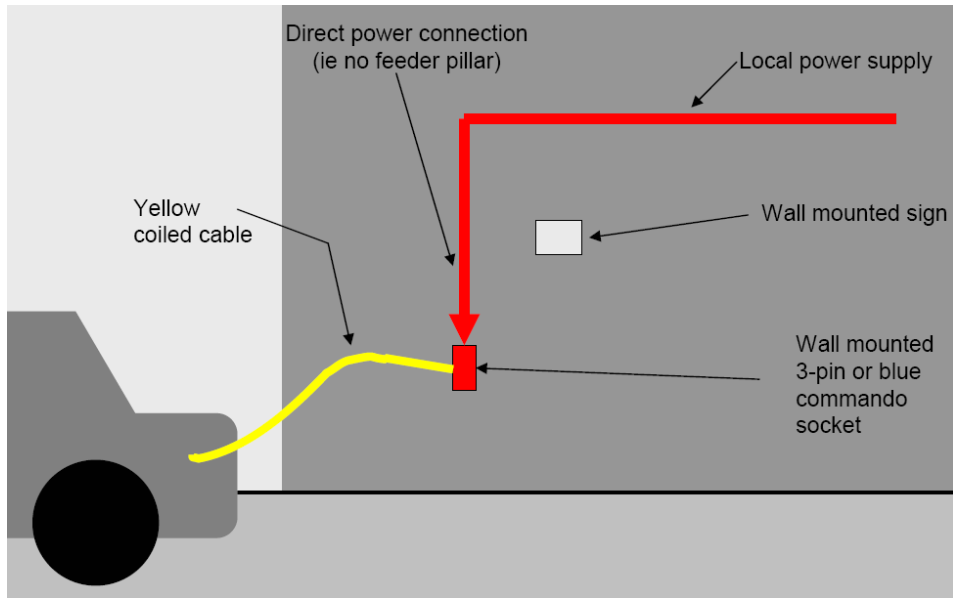

**Figure 2.3 – Components of off-street open access charging points**

**Charging point remote data transfer terminology:**

- RFID = Radio Frequency Identification technology. Enables remote access between the user access tag and EVCPs
- LAN = Local Area Network. Enables communication between closely located charging points
- GPRS = General Radio Packet Service. Technology that enables information to be sent via satellite from one system to another

**2.4 Electricity supply**

2.4.1 The electricity supply is clearly a vital component in the EVCP infrastructure. In simple terms, it consists of three key parts: electricity generation, transmission and distribution. Figure 2.4 helps to explain this process.

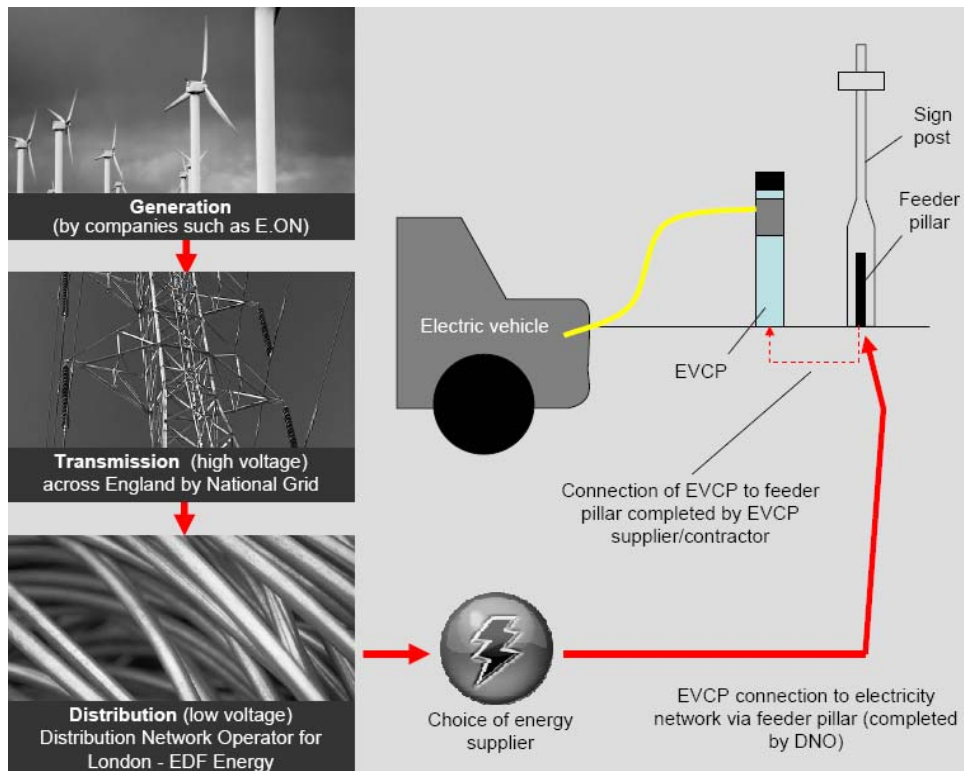

**Figure 2.4 – electricity supply chain**

- 2.4.2 Power in the UK is generated by a range of companies through more traditional sources such as power stations but also using what are considered to be more sustainable sources, such as wind and wave power. This is often referred to as 'green energy'.
- 2.4.3 The electricity is transmitted across England through the National Grid and then distributed locally, often underground, to public and private premises and to installations such as charging points.
- 2.4.4 There are 14 regional distribution networks and EDF Energy are responsible for distributing energy and maintaining the electrical supply system in London (with the exception of Scottish and Southern Energy, who are the distribution network operator (DNO) for parts of West London).
- 2.4.5 Customers have a range of energy supply companies through which they can purchase their electricity, such as npower and Southern Electric. Energy suppliers pay distribution companies, such as EDF, to transport the electricity through the cables to homes, businesses and installations.
- 2.4.6 To operate a charging point, a connection is made from the local electricity network to a feeder pillar. There are currently three types of feeder pillar: external; internal – within the EVCP post; and internal – within a signpost housing. Internal feeder pillars may be used in order to minimise street clutter. So far, only certain suppliers have chosen to manufacture EVCPs with in-built feeder pillars.
- 2.4.7 Open access charging points do not require feeder pillars as the electricity supply is taken from the building on which they are mounted.



**External feeder pillar**



**Feeder pillar in signpost housing**

**Reducing street clutter:**

Feeder pillars can be housed within a modified wide-base signpost in order to reduce street clutter.

## 2.5 Charging point operation

### Restricted access charging points

2.5.1 The main features of restricted access charging points can be grouped into the following four areas:

- User access
- User display
- Remote connection (to supplier operating system)
- Local connection (to other EVCPs<sup>1</sup>)

2.5.2 Users are provided with an access tag by the EVCP supplier. The tag is coded to identify which charging points the user is permitted to use (eg those within the borough to whose scheme they subscribe) and how long their subscription is valid. The user swipes the tag over the display and once their details have been verified the access door to the plug socket unlocks and the electricity is activated. The tag uses Radio Frequency Identification technology (RFID), which means that it does not have to physically connect with the user display.



**EVCP access tag, display & access door**

(Source: Elektromotive Ltd)

#### Aspirations for inter-operability:

It is expected that in the near future all EVCP subscribers will be able to access charging points across all London boroughs. At present subscribers can only access charging points within their local borough or, in some cases, also in neighbouring boroughs (with which they have a common access agreement).

---

<sup>1</sup> Note: as shown in Figure 2.2, the LAN connection is not provided in charging points currently installed in London.

### Operation of charging points:

#### Starting a charging session:

- Plug cable into EV
- Swipe access tag across user display
- Lift access door and plug in cable
- Press access door to lock and to start power transfer

#### Ending a charging session:

- Swipe access tag across user display
- Lift access door and unplug cable
- Press door to lock
- Unplug cable from EV

2.5.3 The user display indicates whether the vehicle is currently charging and for how long it has been charging. Some types of charging points have the technology to disconnect the power once the maximum stay (eg four hours) has been exceeded. In the near future (by communicating information remotely) charging points may be configured to send an automated message to, for example, civil enforcement officers (CEOs) to notify them that a vehicle no longer has permission to use the bay. This is discussed further in Chapter 4.



2.5.4 The information about charging point usage is currently downloaded manually by the EVCP supplier at periods throughout the year, which are defined in Service Level Agreements (SLAs) that are made between the borough and the EVCP supplier. This is because all but a few of the charging points currently installed in London do not have the means to communicate remotely with one another or with a central server. SLAs are discussed in more detail in Chapter 7.

2.5.5 Certain types of charging points have the capability to communicate with one another through a wireless Local Area Network (LAN). To operate a LAN, the charging points must be within a certain range (approx 100 metres) of a 'gateway' charging point. The LAN enables information from the charging point to be fed through one of the gateways using GPRS technology (via a satellite) to the supplier's operating system. Such information may include:

- Number of users per day/week/month
- Visits per user by charging point
- Power consumption
- Whether the charging points are currently in use
- Length of time the charging points have been in use

2.5.6 The first charging points with remote communication functionality have recently been installed in London. The aspiration is that in the near future all charging points in London will be able to communicate information remotely. This means that some of the existing charging points may need to be retro-fitted with the new technology.

- 2.5.7 For the recently introduced charging points with remote communication functionality users can check the supplier's website to find out if the charging points are in use.
- 2.5.8 In future, for all restricted access charging points in London users are likely be able to interrogate the EVCP supplier's/administrator's system online or in-car to identify which charging points are free or when they are likely to be vacated. In addition, users may be able to receive text messages to notify them when their vehicle is fully charged or if the charge has been interrupted. Remote connection capabilities may also enable users to reserve time slots for charging bays.
- 2.5.9 In many boroughs, users can now avoid having to put coins in parking meters by paying with their credit or debit cards by text or phone. In future, using similar technology EV drivers who have not subscribed to an EVCP network may also be able to use a public charging point.
- 2.5.10 Energy suppliers may in future be able to monitor the power usage remotely, which will enable them to manage the distribution on the National Grid more effectively. The administration and monitoring process is described in further detail in Chapter 7.

#### Remote access capability:

Although only available for a small number of charging points currently in use in London, in the near future users are likely to be able to remotely access (in real-time) information about all of London's charging points (eg whether they are in use). Boroughs, EVCP suppliers and network administrators will also be able to benefit from this remote communication functionality.

#### Minimum operating requirements for the pan-London network:

TfL is in the process of defining the minimum requirements for the functionality of charging points that will form the pan-London network. Two of the requirements will be that the charging points must be able to communicate remotely and that there must be a means of monitoring usage for individual users.

### Open access charging points

- 2.5.11 For this type of charging point users simply plug in their vehicles to start charging. The only restrictions are those which apply to the charging bays themselves (eg users may have to pay fees to park and charge their vehicles). Open access charging points may not meet the requirements for the pan-London network, which are discussed in the *London's EV Infrastructure Strategy*.

#### Q. What type of charging point should I install – restricted or open access?

Open access charging points can be used by any EV owner, however it may not be possible to integrate them into the pan-London network. Restricted access points are for the use of subscribers only. **Restricted access EVCPs offer much more to the user and administrator in terms of current/future functionality**, including the ability to monitor power usage (and thereby to charge users for power consumption). Restricted access charging points fit into the model of achieving a London-wide integrated, consistent and intelligent charging point network.

## 2.6 Electric vehicle charging

### Electric vehicles

- 2.6.1 There are many electric vehicles on the market from sports cars, trucks, 4-seater family cars to the more common 2-seater cars, which are known as quadricycles. More information about electric vehicles can be found on the Clear Zones Partnership's Newride website ([www.newride.org.uk](http://www.newride.org.uk)).
- 2.6.2 A popular type of quadricycle is the G-Wiz, which provides up to 48 miles range on a full charge (typically 30-40 miles in normal road conditions, depending on driving style, weather etc).
- 2.6.3 As well as 100 per cent electric vehicles, some boroughs also permit plug-in hybrid electric vehicles (PHEVs) to use public charging points.



Example of 'quadricycle' electric car

### Connection cable and plug types

- 2.6.4 Connection to EVs currently requires the use of a yellow high-visibility coiled cable. This cable has become the standard for use in London, partly due to the fact that it is designed to reduce trip hazards.
- 2.6.5 The cable is fitted at one end with a UK-standard 3-pin domestic plug (to be plugged into the charging point) and at the other end with a specific plug designed to attach to the electric vehicle (sometimes a blue commando). Charging point suppliers provide users with cables to suit their particular electric vehicle.



Yellow cable with blue commando plug

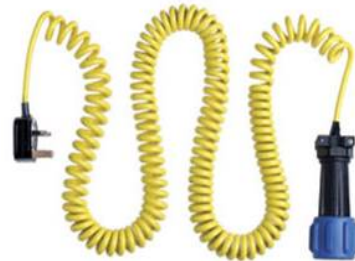

Yellow high-visibility coiled cable (with 3-pin and blue commando plugs)

- 2.6.6 All current restricted access charging points use a 3-pin plug but most open access charging points use a blue commando plug.



3-pin plug socket on restricted access charging point



Blue commando connected to an open access charging point



3-pin plug socket on open access charging point

- 2.6.7 The 3-pin domestic-style square plugs/sockets are certified against BS1363 (rated 13 Amp) whereas the industrial-style blue commando has 3- or 5-pin plugs/sockets (rated 16A, 32A or 63A) and is certified against the international standard IEC60309.
- 2.6.8 For safety reasons both restricted access and open access charging points are fitted with trip switches known as residual current devices (RCDs).
- 2.6.9 A possible future alternative which may remove the need for leads is inductive charging. This requires the vehicle to be in close proximity to the charging point rather than to be physically connected (similar to an electric toothbrush). Inductive charging is being actively developed now, and it is possible that in a few years, vehicles will be able to recharge without a power cord.

### Types of charging

- 2.6.10 The charging points in London currently enable '**standard charging**', which uses a 13A single phase current and on average the charging time is 6-8 hours to achieve a full charge, with a maximum power transfer of one hour's worth of power providing for approximately 10 miles of travel.
- 2.6.11 The maximum permitted stay for on-street charging bays is usually 3-4 hours during the day, in which time users can expect to achieve at least 80 per cent of their vehicle's full charge.

#### Q: How long does it take to charge an Electric car?

It usually takes about 6-8 hours to fully charge an electric car so for most on-street charging bays (where users are permitted to stay for up to three or four hours during the day) they will easily be able to achieve 80 per cent of their full charge.

- 2.6.12 Technology is being developed to also provide '**fast charging**' (32A) and '**rapid charging**' (uses DC rather than AC current). Fast charging should be available in the near future, and as the name implies, it will significantly reduce the charging time (estimated to be 1-3 hours to achieve 80 per cent charge). Rapid charging technology is likely to be a longer-term development and may reduce charge time to around 15 minutes.
- 2.6.13 At present, users are not required to pay for the electricity that they use, however this is unlikely to be sustainable as the charging point network grows. This is discussed further in Chapter 7.

#### Key points:

- Charging points can be on-street or off-street in public or private locations
- Charging points are either restricted access (posts) or open access (sockets)
- TfL is defining minimum operating standards for charging points for the pan-London network
- Restricted access points provide greater functionality and, unlike open access points, can be integrated into the pan-London network
- There are three types of feeder pillars: external; internal – within EVCP posts; and internal – within signpost housing
- Charging points should be designed/located to minimise street clutter
- Users are currently permitted to access EVCPs in certain boroughs – however, the expectation is that they will soon be able to use EVCPs across London
- Technology has been developed for users and network administrators to be able to connect remotely to access information from/about EVCPs
- The yellow coiled cable and 3-pin plug are the current standards used in London
- Technology only permits 'standard charging' at present but 'fast charging' is expected in the near future

## Chapter 3 – Costs, funding and procurement

## 3. Costs, funding and procurement

### 3.1 Introduction

### 3.2 Typical costs

### 3.3 Funding opportunities

- Transport for London LIP
- Central Government
- Private sponsorship
- European Union

### 3.4 Procurement

#### 3.1 Introduction

3.1.1 This chapter is structured to firstly identify the typical costs involved in introducing and operating charging points and then to document the potential sources of funding.

#### 3.2 Typical costs

##### Infrastructure costs

3.2.1 Table 3.1 shows the scale of cost for introducing the different types of charging points that were described in Chapter 2. Table 3.2 provides an indication of the costs for the equipment and installation.

**Table 3.1** – Cost level for charging point types/locations

Type	On-street/ off-street	Public/ private	Shared	Restricted access (RA)/Open access (OA)	Plug type	Cost level	
						Equipment	Installation
A	On-street	Public	Yes	RA	3-pin	High	High
B	Off-street	Public	Yes	RA/OA	3-pin/blue commando	Medium/high	Medium/high
C	Off-street	Private	Yes	RA/OA	3-pin/blue commando	Medium/high	Medium/high
D	Off-street	Private	No	OA	3-pin/blue commando	Medium/low	Medium/low

**Table 3.2** – Costs for EVCP equipment and installation

Cost level	Cost (approx)	
	Equipment	Installation
Low	£0 – £500	£0 – £500
Medium	£500 – £1,000	£500 – £1,500
High	£3,500 – £4,000	£3,000 – £5,500

3.2.2 The wide variation in the cost of purchasing and installing charging points can be attributed to several factors, but the one that has by far the most significant impact is whether the charging points are restricted access or open access types. The restricted access charging

points have significantly higher capital costs and installation costs than open access points as there are additional costs associated with the purchase and implementation of feeder pillars<sup>1</sup>. The low- and medium-cost cost levels apply to open access charging points.

3.2.3 Other factors which may contribute to the variation in capital costs and installation costs are listed as follows:

#### Capital costs

- Type of feeder pillar: external feeder pillar; internal feeder pillar (in EVCP) or feeder pillar in signpost
- Single or twin charging point
- Whether charging point has remote communication functionality (either LAN or gateway charging point – see Chapter 2 for description)
- Type of restricted access charging point – there are a range of suppliers (see Chapter 4 and Appendix D)
- Type of open access charging point – 3-pin or blue commando

#### Installation costs

- Connection distance/routing from mains electricity network to feeder pillar
- Type of footway/car park surfacing material (requiring reinstatement)
- Number of EVCPs installed at one site (lower cost per charging point when more than one charging point installed)
- Signage location – on existing signpost, lamp column etc or on new signpost (or wall mounted)

3.2.4 Table 3.3 provides a more detailed breakdown of the costs for the different types of charging point.

**Table 3.3** – Indicative cost breakdown (equipment and installation costs)

Item	COST £ (approx)					
	Restricted/open access		Charging point type			
	Restricted	Open	A On-street Public Shared RA	B Off-street Public Shared RA/OA	C Off-street Private Shared RA/OA	D Off-street Private Not-shared OA
Charging point equipment	3,500	500	3,500	3,500/500	3,500/500	0-500
Charging point installation	1,000-1,500	500	1,500	1,000/500	1,000/500	0-500
Feeder pillar equipment	500	0	500	500/0	500/0	0
Feeder pillar installation	300-500	0	500	300/0	300/0	0
Connection mains – feeder pillar	1,000-1,500	0	1,500	1,000/0	1,000/0	0
Connection/commissioning feeder pillar – EVCP	500	0	500	500/0	500/0	0
Road signs	100-200	100	200	200/100	100	0
Bay road markings	200-500	200	500	200	200	0
EVCP branding and logos	0-200	0	200	200/0	0	0
Traffic management order	0-500	0-500	500	500	0	0
<b>Total Cost £ (approx)</b>	<b>7,100-9,400</b>	<b>1,300-1,800</b>	<b>9,400</b>	<b>1,800-7,900</b>	<b>1,300-7,100</b>	<b>0-1,000</b>

Equipment costs (other costs are classed as installation costs)

<sup>1</sup> some restricted access charging points have built-in feeder pillars, therefore these charges would not apply

3.2.5 Table 3.3 includes costs for installation of power from the mains supply to the feeder pillar. Whereas most of the cost components can be estimated with a reasonable degree of accuracy, the costs for the power connection may vary significantly. This is because they involve groundworks which, until construction starts, are inherent with unknowns such as the requirements for re-routing around other services, across private land, across the road etc, and the requirements for temporary traffic management measures.

3.2.6 The energy distribution network for London is detailed on drawing plans, which may help to inform the selection of charging point sites across the borough. The cost viability of a proposed charging point location can be determined to a certain extent by its proximity to lamp columns, traffic signals and other types of equipment that require a mains power connection. Once a charging point site has been selected then the energy distributor should be contacted to provide a cost estimate for connection to the charging point.

### Operational costs

Open access charging points:

3.2.7 All of the public open access charging points in London are located in car parks and in most cases EV users have to pay hourly or annual parking fees to charge their vehicles. Prior registration is not normally necessary although EV users would need to register for the annual parking schemes in the same way as drivers of petrol-fuelled vehicles. EV users usually benefit from reduced parking fees at open access charging points.

3.2.8 For boroughs, the operational costs for public open access charging points are at present relatively small as they only involve periodic maintenance of the charging points, signs and road markings and costs for power usage.

Restricted access charging points:

3.2.9 The operational costs for restricted access charging points are summarised in Table 3.4.

3.2.10 The costs vary among boroughs but in most cases users pay an initial joining fee for the borough's charging point network to cover the cost of a permit, a charging cable and access tags for the charging points. Subscribers need to display a permit to demonstrate that they are permitted to use charging bays in a particular borough/s. For many boroughs, the permits also qualify users for free parking or parking concessions in other locations (ie not charging bays). Examples include reduced price or free residential parking, reduced price season tickets for car parks and free parking in pay and display bays.

3.2.11 In addition to the joining fee, the users pay an annual administration fee for the network. The initial and annual fees are usually paid to the EVCP supplier who administers the network on behalf of the borough. Some boroughs have arrangements with neighbouring boroughs which enable subscribers to use charging points across all of the collaborating boroughs.

3.2.12 The local authority pays a monthly and annual fee to the EVCP supplier for administering their network, which involves:

- Issuing the cable and access tags to the user
- Processing initial/annual subscription payments
- Operating a user helpline

- Maintaining the charging points
- Providing regular reports to the borough on charging point usage

- 3.2.13 The information on usage is downloaded manually at present but as remote communication functionality is introduced the administration charges for this are likely to reduce. The administration fees are not currently linked to the number of charging points that are in operation, however this is likely to change as the charging point network grows.
- 3.2.14 At present, users do not have to pay for the electricity they consume while charging. As demand grows this situation is likely to be unsustainable. If users are required to pay for their electricity consumption then this may influence when they choose to charge their vehicles, given that electricity charges are higher during the day.
- 3.2.15 The borough must pay the energy supplier for the power used, however these costs are negligible given that there are relatively few users and charging points at present.
- 3.2.16 The administration costs are defined in the SLA and should be reviewed by the borough on an annual basis.

**Table 3.4** – Operational costs for charging points

Payer	Payee	Item	Cost
Subscriber	EVCP supplier	Joining fee & EV permit	£50-£100*
Subscriber	EVCP supplier	Annual admin fee	£17-£75 per year
Borough	EVCP supplier	Admin fee	Approx £3,000 per year
Borough	Energy supplier	Power usage	Negligible (varies**)

\* For some boroughs this includes an annual subscription charge and all or part of the fee is taken as a deposit. Certain boroughs charge separately for the permit, which is paid directly to the borough.

\*\* Costs for electricity vary according to number of/usage of charging points. Annual cost for 20 per cent occupancy of one charging point is approximately £500.

- 3.2.17 The vast array of administration charges, parking concessions and arrangements between boroughs can be confusing for subscribers and off-putting for potential EV users. To address this issue, a pan-London administration system is planned to be introduced in 2011. The system will operate using a more standardised and simplified set of charges for boroughs and subscribers.
- 3.2.18 The administration of charging points is discussed in further detail in Chapter 7.

#### Pan-London administration system:

The proposed pan-London EVCP network will incorporate a London-wide EVCP administration system. The system will operate using a more standardised set of charges for local authorities and subscribers.

#### Charging for electricity consumption:

At present EV users do not pay for the electricity they consume at charging points (other than at home). However, as demand increases this situation will be unsustainable and, as such, in future boroughs are likely to charge for energy consumption.

### **3.3 Funding opportunities**

- 3.3.1 Most of the public charging points in London have been implemented using TfL Local Implementation Plan (LIP) funding. However, several other funding sources exist. Several boroughs have taken advantage of these other sources to part/match fund the installation of charging points. Information on the alternative funding sources is provided below. For further details on funding, borough officers should contact Omoniyi Giwa, TfL Programme Manager for Surface Transport (Better Routes and Places) – contact details shown in Appendix D.

#### **Transport for London LIP funding**

- 3.3.2 Boroughs receive funding from TfL for transport projects through the Local Implementation Plan process. TfL determines the LIP funding that each borough will receive partly using a formula-based approach. A funding announcement is made each year and the formula-based allocation is split into Corridors, Neighbourhoods and Smarter Travel. Outside of the formula-based allocation boroughs also receive funding for Principal Road Maintenance and Major Schemes.
- 3.3.3 Once the annual funding announcement is made by TfL, boroughs have discretion to determine which schemes under the three formula-based programmes they want to progress using the funding. Boroughs set this out in a submission to TfL in September each year, to which TfL provides a response by December.
- 3.3.4 Boroughs would normally include charging point schemes within the Neighbourhoods or Corridors programmes, although they can also be included in Major Schemes or as part of an integrated Smarter Travel programme.

#### **Central government funding – ‘Plugged in Places’**

- 3.3.5 Plugged in Places is a £30m government fund that aims to trail blaze electric vehicle technology in the UK by providing grants to cities who wish to increase the level of their electric vehicle infrastructure.
- 3.3.6 The Government set aside £20m from its consumer incentive programme for the Plugged in Places EV infrastructure framework – with up to a further £10m from the Low Carbon Strategic Investment Fund.
- 3.3.7 The funding is being allocated to lead cities or regions to establish themselves as front-runners trialling and adopting EV recharging infrastructure. The funding is available to consortia made up of local authorities, regional development agencies and private businesses. It will be expected that a range of on-street and off-street locations are used and that different solutions to charging are implemented.
- 3.3.8 In February 2010, in the first round of funding the Department for Transport awarded a £9.3 million grant to London under the Plugged in Places programme to deliver 7,500 electric vehicle charging points in the capital.
- 3.3.9 The second round of Plugged in Places funding remains open to bids from new consortia, and will be assessed later in 2010.

### Private sponsorship

- 3.3.10 Some boroughs have chosen to enter into a sponsorship agreement for their charging points with the energy distributor EDF. The agreement is for five years and in return for the funding EDF Energy require branding to be included on the charging points. Boroughs can terminate this at the end of this period by giving 14 days' notice. The agreement stipulates criteria that some boroughs may find quite demanding.
- 3.3.11 Consideration is being given to wider sponsorship agreements as part of the pan-London scheme. Boroughs should be mindful that any sponsorship agreements that they enter into could preclude their involvement in a future pan-London sponsorship.

### European Union funding

- 3.3.12 The Seventh Framework Programme for Research and Technological Development (FP7 for short) is the European Union's (EU) main instrument for funding research in Europe and runs from 2007 to 2013.
- 3.3.13 Through FP7 the EU has launched the European Green Cars Initiative, which is a series of measures boosting research and innovation to deploy a new generation of passenger cars, trucks and buses that will benefit the environment and create jobs. One of the initiatives' strategic objectives is for the 'electrification' of road and urban transport.
- 3.3.14 The London European Partnership for Transport (LEPT) worked with TfL and other European partners to coordinate a bid to gain EU funding for a small consortium of European cities (including London) to undertake a demonstration project, which would assist with the acceleration of the market roll-out of electric vehicles. As well as contributing to the evaluation of the viability of accelerating the take-up of EV technology, the project would also help to identify standards and requirements for a charging infrastructure across Europe.
- 3.3.15 The project budget would be €40m, of which €23m would come from EU funding. The €17m non-EU funding would include match funding from boroughs and TfL. Project components may include schemes such as trialling fast-charge sites at supermarkets, introducing car club charging points and using in-car satellite navigation systems to locate available charging points.
- 3.3.16 The bid was submitted in early 2010 with an announcement due later in the year.



#### Funding options:

The main source of funding for borough charging networks is Transport for London LIP funding. However, boroughs should explore opportunities for gaining complementary funding through other UK and European sources.

### 3.4 Procurement

- 3.4.1 Boroughs are able to procure charging points from EVCP suppliers in the same way as any other LIP funded equipment or infrastructure. Historically, competitive tendering has not been required as there has only been one supplier in London. However, further suppliers are

now coming into the market, which can contribute to the expansion of the charging point network in London.

- 3.4.2 With the aim of achieving discounts on the purchase of charging point infrastructure, opportunities should be explored for bulk procurement of EVCP infrastructure. For example, in 2009 on behalf of several boroughs the Cross River Partnership (via Westminster Council) invited tenders for bulk purchasing of charging points from several suppliers. The application was for the equipment only and did not include installation or administration. Boroughs separately arranged for installation of the charging points and signed individual Service Level Agreements with the suppliers.
- 3.4.3 The pan-London scheme will have a bulk-procurement framework contract that boroughs can use for purchasing charging points.

#### Key points:

- Costs for charging point equipment and installation vary significantly, and largely depend on whether they are restricted access (high cost) or open access (low cost) and according to the connection distance/routing from mains electricity network to the feeder pillar
- The cost to purchase and install an on-street restricted access charging points is in the region of £10k
- The public restricted access charging points are located in car parks and EV users have to pay hourly or annual parking fees (albeit often reduced) to charge their vehicles
- Users subscribe to use restricted access charging points and pay an initial fee (for a permit, charging cable and access tags) as well as an annual admin fee
- The EV permit often qualifies users for free parking or parking concessions in other locations (ie not charging bays)
- The borough pays a monthly/annual fee to the EVCP supplier for administering their scheme
- There are plans to introduce a pan-London EVCP administration system which permits subscribers to use any charging point in London and would operate using a more standardised set of charges for boroughs and subscribers
- At present EV users do not pay for the electricity they consume at charging points (other than at home). As demand increases this situation will not be sustainable and as such at some point in the future boroughs are likely to charge for energy consumption
- In addition to TfL LIP funding there are several other funding sources for procuring EVCP infrastructure
- Boroughs should consider opportunities for bulk procurement of EVCP infrastructure. The pan-London scheme will have a bulk-procurement framework contract

## Chapter 4 – Location and design considerations

## 4. Location and design considerations

- 4.1 Introduction
- 4.2 Location of charging points
- 4.3 Planning legislation
- 4.4 Parking controls
- 4.5 Typical layout details
- 4.6 Impact on streetscape
- 4.7 Consultation
- 4.8 Enforcement
- 4.9 Charging point suppliers and energy distributor
- 4.10 Timescales

### 4.1 Introduction

- 4.1.1 In Chapter 2, a description was given of the different types of charging points that are in operation. This chapter covers all types of charging point but focuses on public restricted access charging points. This is because they offer more benefits to the user, borough and network administrator in terms of current and future functionality. This includes the ability to monitor power usage and thereby, if required, to introduce a tariff for power consumption.

### 4.2 Location of charging points

#### Potential locations for charging points

- 4.2.1 Locations which may be suitable for introducing charging points include the following:

#### On-street – public and shared charging bays

- Town centres, high streets, tourist attractions
- Residential areas (including car club bays)

#### Off-street (car parks) – public and shared charging bays

- Leisure centres and sports facilities
- Retail outlets
- Community facilities
- London Underground and Overground rail stations
- Parks and other green spaces
- Education facilities

#### Off-street (car parks) – private and shared charging bays

- Workplaces
- Residential apartments (including car club bays)

#### Off-street – private charging bays

- Residential



- 4.2.2 The demand for the charging point sites will be dictated by the users' journey purpose. To achieve about 80 per cent of the vehicle's full charge users will need to charge for about three hours, which is the maximum permitted stay for most of the existing on-street charging bays. Therefore the most suitable locations are those which have the above-listed attractors nearby (where users are likely to spend up to three or four hours).

#### **Initial selection of charging point locations**

- 4.2.3 In order to select the most suitable sites for on-street and off-street public charging points across a borough a desktop evaluation should be undertaken that takes account of the following factors:

- **Demand** (existing/potential) for charging points, dependent on: clustering of current EV users (if known); expected future demand from new users and proximity to existing charging bays
- **Visibility/accessibility** – highly visible, accessible and busy locations desirable. This increases public awareness and also means there is better natural surveillance (improving personal security)
- **Road space** – avoid displacing existing parking bays if at all possible (unless currently under-utilised or can be replaced nearby). Do not locate the bays too close to junctions or where they will cause disruption to the flow of traffic
- **Footway space** – consider whether introducing charging points will reduce the effective footway width to an unacceptable level
- Potential to create **Green Hubs** (with cycle parking, car club bays, recycling areas etc)

- 4.2.4 In busy high streets there is usually a high demand for kerbside space and it may be difficult to find a suitable location for a charging point that is not currently occupied by a well-utilised parking bay. This is likely to be a similar issue in public car parks.

- 4.2.5 If it would be necessary to displace a parking bay then the potential loss in parking revenue should be considered.

- 4.2.6 Figures 4.1 to 4.3 summarise the factors shown above and provide examples of model locations for on-street and off-street EVCPs.

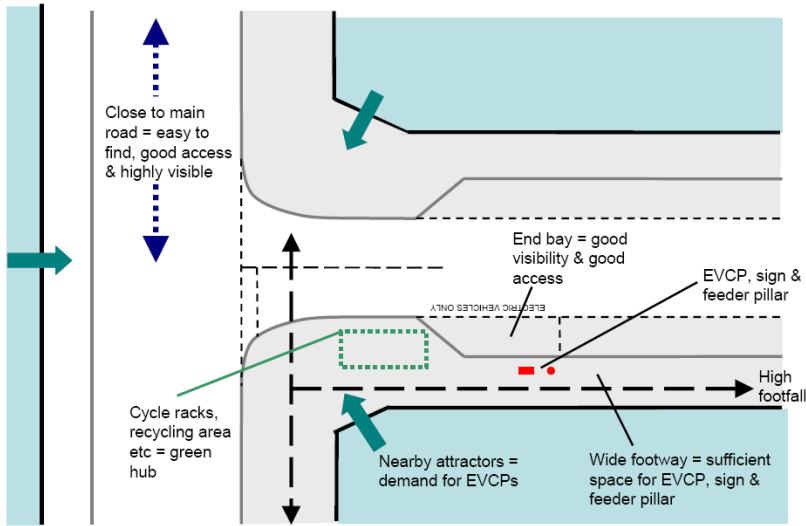

Figure 4.1 – Model on-street EVCP location



**Charlotte Street, Camden**  
End bay, busy street, near main road and close to shopping area and offices

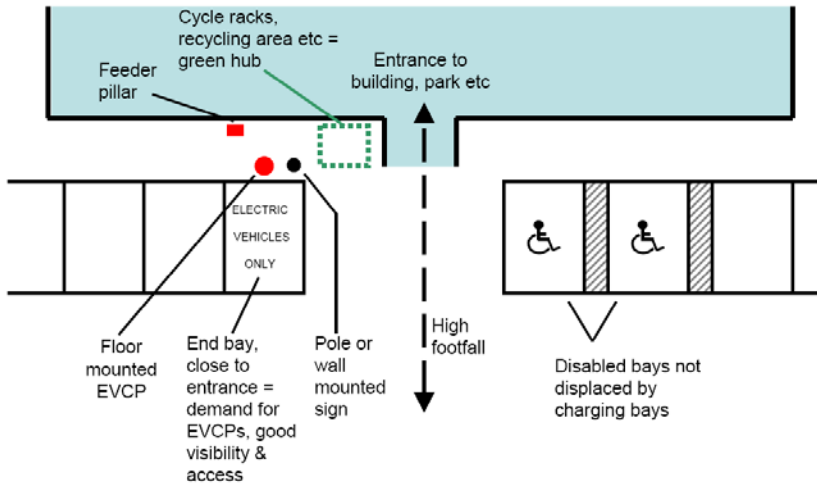

Figure 4.2 – Model off-street EVCP location – external car park



**Wandle Recreation Centre, Wandsworth**  
End bay, close to entrance

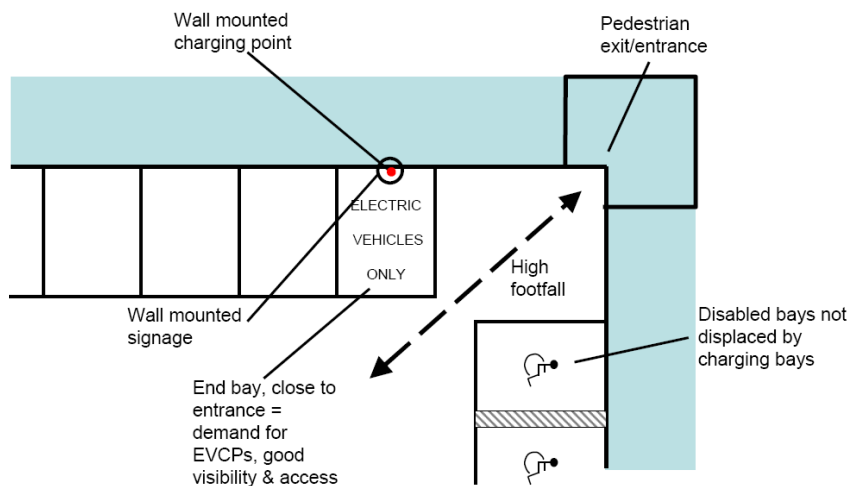

Figure 4.3 – Model off-street EVCP location – internal car park



**Putney Leisure Centre, Wandsworth**  
At entrance to multi-storey car park

## TfL charging point location strategy:

As part of their plans to introduce a pan-London charging point network, TfL is developing a charging point location strategy. This will help to determine the locations where demand is likely to be greatest for on-street and off-street public and private charging points. Demand is likely to be based on factors which include: household income; journey to work patterns; trip length; on-street parking capacity and the distribution and size of workplaces. The work completed to date is summarised in the draft *London's EV Infrastructure Strategy*.

### Site audits

4.2.7 As noted earlier, a desktop review should be used to select locations which appear to be suitable for introducing charging points but it will be necessary to undertake site audits to confirm this. The site audits should be used to make observations related to the following:

- **Layout/location** of charging bay – can the bay be introduced on existing single/double yellow lines rather than displacing a well-used parking bay? Can a poorly utilised parking bay be used? Can the charging bay be introduced at the end of parking bays?
- **Land ownership** (may impact on potential routes for electricity connection)
- Current **parking controls** – consider how the new parking restrictions that will be required will fit in with the existing restrictions
- **Electricity connection** – how easy will it be to connect the EVCP to the mains supply network? (indicated by proximity of lamp columns, traffic signals etc)
- Location of other **utilities** eg gas, telephone (indicated by service covers) – may impact on feasibility/cost of electricity connection
- Location of **street furniture** (identify locations for sign fixing and aim to avoid clutter)
- **Footfall** – how many people regularly pass by the proposed location?
- **Pedestrian crossing** activity (potential safety issues with extended charging cable)
- **Proximity to short stay attractors** (eg public transport stops/stations, banks) – more likely for bays to be abused by non-EV users if closet to these attractors
- **Context** of surroundings (eg sensitivity regarding historic buildings) – charging bays should not impact negatively on the streetscape



**Wilton Street, Westminster**  
Wide footway and uncluttered street. Feeder pillar in signpost housing



**Berkeley Square, Westminster**  
End bay, next to shops and offices, high footfall, famous London Square, good natural surveillance

- 4.2.8 Some boroughs may feel it beneficial to undertake the site audit together with the EVCP supplier, although in some cases this is likely to be impractical. It may be necessary to involve other stakeholders in the process, especially if the charging points are to be located on private land (eg supermarkets), in which case contributions to the cost of the infrastructure should also be sought.
- 4.2.9 Following identification of the proposed site(s) initial enquires may be made with EDF Energy, the electricity distributor for London, for a preliminary assessment of the new connection and to obtain a quote. When the request for a new connection is made to EDF they will provide the customer with a meter point administration number (MPAN).
- 4.2.10 It is advisable that contact with EDF should be made before the designs are finalised and the Traffic Management Order (TMO) is advertised. If difficulties with the electricity connection can be foreseen then alternative solutions (or locations) may be chosen, thereby avoiding unnecessary costs.

#### Contact with energy distributor:

In order to mitigate the likelihood of delays related to energy connections, contact should be sought early on with the energy distributor EDF – ideally as soon as the charging point location has been identified.

- 4.2.11 As discussed in Chapter 2, the ease of access to the mains electricity network is an important consideration as it has a bearing on the installation cost of the charging points. If lamp columns, traffic signals and other equipment which require mains power are located close by then this is usually a good indicator that the connection should be relatively straightforward (and therefore not prohibitively expensive).
- 4.2.12 It is expected that in the near future all restricted access charging points will have the functionality to communicate remotely. Consideration should be given to whether the choice of location will restrict the charging point's ability to communicate information. Charging points will communicate with one another using a LAN, which requires them to be located within a certain distance of one another (thought to be about 100 metres). The LAN will connect to a gateway charging point which will transmit information via satellite to a server. As with mobile phone technology, certain locations (eg multi-storey car parks) may not provide a sufficiently strong satellite signal for this connection to be made.

### 4.3 Planning legislation

- 4.3.1 The research report published by the Department for Communities and Local Government (DCLG) in November 2009 – *Review of permitted development for charging points for electric cars* – informs that existing permitted development and advertisement regulations are not designed to govern EV charging points and therefore are not very well suited to this purpose.
- 4.3.2 Local authorities consulted as part of the research said that no significant planning issues have arisen from private installations and that it appears that off-street charging points have been treated by planning authorities as 'not development'. This is generally because they have been located in multi-storey car parks.

4.3.3 Westminster City Council (through the Clear Zones Partnership) has led the way with trialling on-street charging points. The DCLG report attached significance to the fact that none of the charging points in Westminster were installed with a planning application. Rather, the suitability of charging points was based on factors which included:

- Compliance with the 'Westminster Way' street design guidelines
- Suitability for disabled users
- Charging point compatibility with the majority of EVs used in London

4.3.4 In general, from a planning perspective the major impact of charging points to date is considered to be their visual appearance and street clutter in public areas.

4.3.5 As discussed in the research report, the regulations appear to permit without the need for an application to the local planning authority the following:

Charging points:

- Charging points within a 'building' (which could be a multi-storey car park)
- An external plug (eg on the front face of a dwelling)
- Charging points that are provided and operated by the local planning authority as a public service

Charging point signs and advertisements:

- Operating instructions for on-street charging points provided by local authorities
- Signs, not exceeding 4.6m<sup>2</sup> on business forecourts relating to the service or goods provided
- Advertisements within enclosed spaces (including car parks) that are not 'readily visible' from the outside

4.3.6 The DCLG report concludes that 'as the regulations stand, charging points and signage on them that do not meet these criteria would require an application to the local planning authority'.

4.3.7 Advertising regulations provide only for operating instructions to be displayed on on-street charging points. In practice, such charging points in Westminster carry a modestly sized neutral EDF logo and, Westminster City Council did not seek an application for advertising consent for these. Camden Council appears to have taken stricter interpretation of the regulations and would request an application for such a sign.

4.3.8 The DCLG report led to publication in November 2009 of a consultation paper<sup>1</sup> that presented a series of policy options, which have a common rationale:

**“ Government intervention is necessary to clarify the status of electric vehicle charging infrastructure in planning and advertising legislation and to ensure that planning does not act as a disincentive to the installation of charging points. ”**

*(DCLG consultation paper<sup>1</sup>, November 2009)*

---

<sup>1</sup> *Permitted development rights for small-scale renewable and low carbon energy technologies, and electric vehicle charging infrastructure*, Department for Communities and Local Government consultation paper, November 2009.

- 4.3.9 Borough planning officers should be consulted regarding planning permissions for charging point sites.

## 4.4 Parking controls

### Parking restrictions

- 4.4.1 Parking controls for charging bays vary across boroughs, depending on where they are located (eg in town centres, in residential areas). The most common restrictions are those shown in Figure 4.4 where EV permit holders are allowed to park and charge for free (albeit they must pay for their annual permit – see 4.4.5) for a certain period (usually 3-4 hours) during certain hours of the day/days of the week. Outside of these hours they can park/charge for as long as they like. These restrictions are normally used for on-street bays.
- 4.4.2 A variation of these restrictions is shown in Figure 4.5, where EV users can park/charge for free for a certain period (in this case four hours) but are not restricted to hours/days of the week. Figure 4.6 shows another variation where EV users must pay to park to charge their vehicles. This restriction is often used in public car parks.
- 4.4.3 In all three examples, the bays can only be used by drivers displaying EV permits, which are issued by the borough. While a standard sign face layout has been adopted by London boroughs that operate EVCPs, type approval is currently required from the DfT to use these signs. However, a consultation document<sup>2</sup> was published by the DfT in September 2009 which proposes variants to existing signs and road markings contained in the Traffic Signs Regulations and General Directions (TSRGD) 2002 to permit the use of the words 'Electric vehicles'. It is likely that signs closely resembling those shown in Figures 4.4 to 4.6 will soon be regulatory.



**Figure 4.4 – Sign type 1:**  
max stay, limited during certain hours/days



**Figure 4.5 – Sign type 2:**  
max stay, no return on same day



**Figure 4.6 – Sign type 3:**  
max stay, limited during certain hours/days – with parking charge

- 4.4.4 Open access charging points (located in internal car parks eg multi-storey) are not normally restricted to a maximum charge duration or hours of the day/days of the week. EV users are not normally required to have a permit to park in these bays but they will usually have to pay a parking fee.

<sup>2</sup> Traffic Signs (Amendment) Regulations and General Directions (TSRGD) 2010 consultation document, September 2009

#### Typical parking controls used for charging bays:

- No restrictions but parking charges apply (usually in multi-storey car parks)
- Maximum stay (eg up to three or four hours), for certain hours of day/days of week, free parking
- Maximum stay (eg up to three or four hours), no return on same day, free parking
- Maximum stay (eg up to three or four hours), parking charges during certain times

#### Restrictions and requirements for parking in charging bays:

- Charging bays can only be used while actively charging electric vehicles
- For most charging points (particularly those located on-street) drivers must display an EV permit (obtained from the borough)
- EV users are usually permitted to charge for certain periods only (up to three or four hours)

### Parking permits

- 4.4.5 Certain boroughs charge a fee for EV permits (£11 to £50 per year), whereas others provide permits for free. This charge is sometimes included within the annual subscription cost for the borough charging scheme (see Table 3.4). Depending on the borough concerned, eligibility for permits is restricted to residents only, or in some cases, for those who work in the borough.
- 4.4.6 Westminster City Council run a club called 'Eco-Mark' for people with alternatively fuelled vehicles (electric, gas or hybrid). Any EV users that have joined Eco-Mark are eligible to use the borough's charging points.
- 4.4.7 Many boroughs offer EV users parking concessions for non-charging bays (eg normal pay and display bays or car parks).
- 4.4.8 Camden Council issues two types of EV permit, one that allows free parking in charging bays and another that allows free parking in pay and display bays (in the north of the borough). The pay and display permit is only available to holders of a resident's parking permit.
- 4.4.9 Some boroughs have arrangements with neighbouring/allied boroughs that allow EV permit holders to use any of the charging bays within the collaborating boroughs. For example, the London boroughs that form the South and West London Transport Conference (SWELTRAC) have agreed that EV users can charge in any of the ten partnership boroughs.

#### Future technical advancements:

With future technical advancements for charging points it may be possible for non-registered as well as registered EV users to pay by text or phone to use a charging bay. Such advancements may also enable users to book charging bays in advance for a certain period (similar to car clubs).



### Good practice principles for designing the layout of on-street charging bays:

- **Angle of EVCP and height of controls:** position the charging point at 45 degrees to maximise accessibility (for disabled as well as non-disabled users). As with parking meters, the controls should be at a height which permits access by wheelchair users
- **Street clutter – feeder pillar:** to minimise street clutter incorporate feeder pillar into modified (wide-based) signpost housing (or where possible use charging point with integrated feeder pillar)
- **Effective footway width – feeder pillar:** where separate feeder pillar is used locate so as to not obstruct access to charging point or pedestrian movement on footway – consider locating at back of footway
- **Sign plate location:** where possible, locate sign plate on existing signpost/lamp column or on wall (assuming integrated signpost/feeder pillar not used)
- **Kerbside obstructions – charging cable:** locate feeder pillar no more than 0.45 metres from kerbline to minimise extension of charging cable
- **Contact details – feeder pillar:** feeder pillar to show borough and EV supplier contact details
- **Sign plate details and road markings** – currently require type approval from DfT but formal recognition proposed in DfT consultation document. Road markings likely to be a variant of TSRGD no. 1028.4



**Wall mounted sign**  
– minimising street clutter



**Short cable extension**  
– minimising trip hazard



**Contact details**  
– EVCP supplier hotline and borough contact

### Off-street charging points

- 4.5.4 The typical layout details for off-street restricted access charging bays (located in external car parks) are shown in Figure 4.8.
- 4.5.5 Unlike on-street charging bays, the off-street bays are not on the public highway and therefore the signs and road markings do not have to conform to the Traffic Sign Regulations.
- 4.5.6 However, to assist users in locating the charging bays and in interpreting the parking restrictions it is good practice to



**Off-street restricted access charging point in car park**

(source: Infracharge Ltd)

ensure there is a degree of consistency in the layout, colour and dimensions of the road markings and signs that are used across the borough. This will also help to dissuade non-users from parking in the bays.

4.5.7 The dimensions of the parking bay shown in Figure 4.8 are the minimum typically recommended for car parks in local planning guidance and published guidance documents such as *Manual for Streets, 2007*, DfT. These dimensions will usually be specified in the planning application for the car park/development.

4.5.8 Figure 4.8 shows both floor and wall mounted charging points. As with on-street bays, the floor mounted charging points can have a separate feeder pillar, a pillar located in a signpost housing or an integrated feeder pillar. There are generally fewer issues regarding sign clutter in car parks and as such a separate feeder pillar may often be the preferred option.

4.5.9 For charging bays that are located close to buildings, it may be suitable to use a wall mounted charging point which draws power directly from the building (rather than using a feeder pillar). It is good practice to use a metal cage to protect the charging points. Wall mounted charging points are also used in internal car parks.



Wall mounted charging point with protective cage

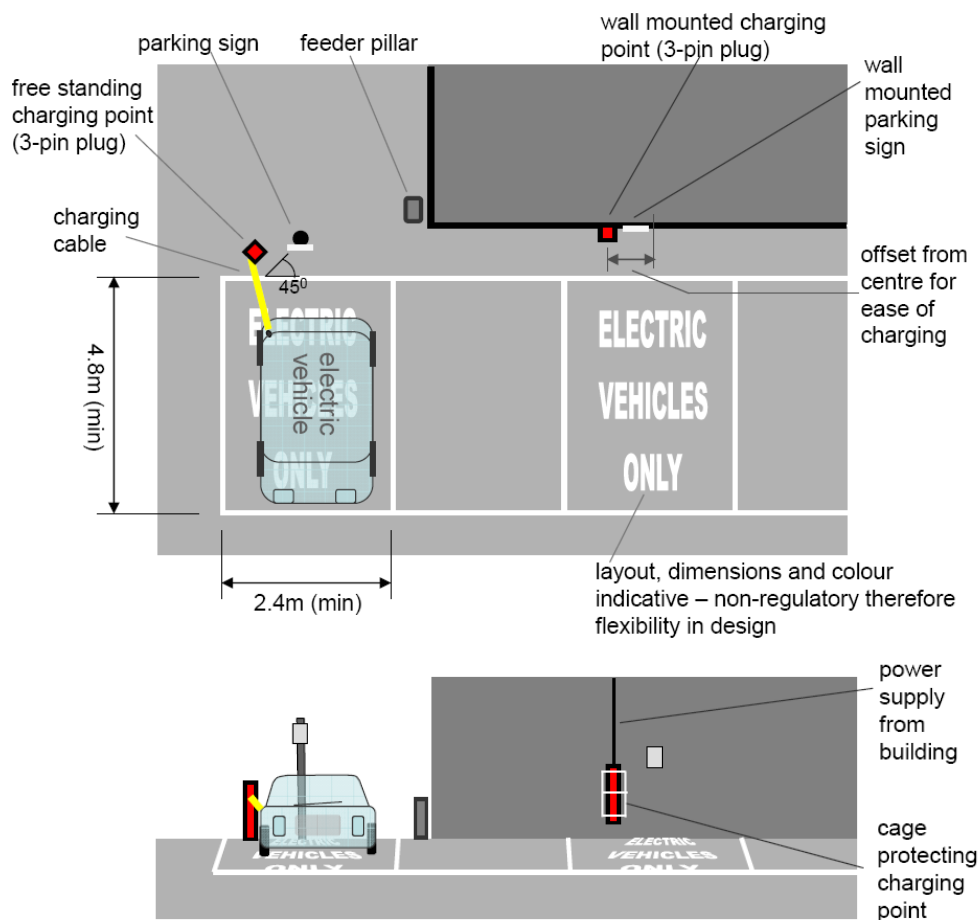

Figure 4.8 – Plan and elevation showing typical layout details of a restricted access **off-street** charging bay in external car park

## External or internal feeder pillar?

4.5.10 As described earlier, there are three types of feeder pillar: external; internal – within the EVCP post; and internal – within a signpost housing. The factors that impact on the choice/suitability of the feeder pillar type include the following:

- Impact on street clutter – external feeder pillars may add to street clutter
- Streetscape/public realm sensitivity – the modified signpost housings reduce clutter but may be detract from the streetscape in visually sensitive locations
- Footway space – if constrained then an integrated pillar may be the best solution
- On-street or off-street (public) location – clutter may be less of an issue in an off-street car park
- Proximity to buildings for off-street (public) locations (if charging point can be wall mounted then feeder pillar not required)

4.5.11 It should be noted that at present only certain suppliers provide charging points with built-in feeder pillars. Some suppliers consider that it is not advisable to have an internal feeder pillar for reasons which include:

- Independent/easy access must be provided for the utility company in case of emergency to enable grid isolation/unit isolation
- Maintenance of internal feeder pillar by utility company may be more difficult
- More difficult to take meter readings
- A greater degree of communication/coordination is required between the EV supplier and electricity distributor as the installation of power cannot be carried out in isolation from the charging point

## 4.6 Impact on streetscape

4.6.1 In recent years TfL and boroughs have placed greater importance on streetscape issues. Most boroughs have developed their own street design guides and these are complemented by numerous other good practice documents including TfL's *Better Streets*, the TfL *Streetscape Guidance* and the DfT's Local Transport Note 1/08 *Traffic Management and Streetscape*.

4.6.2 Many of the principles of good design are generic and therefore apply to charging points in the same way as other types of traffic management equipment and street furniture, particularly for on-street charging points.

#### Good practice principles include:

- In selecting the **type of charging point**, consider how well the design (size, shape, colour) will fit in with its surroundings
- Where possible, **fix signs to existing sign poles**, lamp columns or mount on walls (subject to obtaining necessary permissions). Consider using internal feeder pillar
- Ensure **consistency** with other street furniture (charging points can come in several colours, but are usually black or silver)
- **Minimise** number of size of signs required (less is more) – while ensuring functionality
- Design in accordance with borough and TfL **streetscape guidance**
- Consider **context** of surroundings (eg will it fit in with adjacent historically significant buildings?)
- Consider **whole-life costs** (ie how easy/costly will it be to maintain?)
- Take measures to **reduce likelihood** of the equipment, signs etc **being defaced** (eg use anti-graffiti paint, locate signs at correct height)

4.6.3 In future, it may be possible to further reduce street clutter by combining charging points with pay and display machines and by locating feeder pillars underground (a practice occasionally adopted for traffic signal controllers).



**Cadogan Road, Woolwich**  
Integrated feeder pillar within the EVCP post  
(Source: Infracharge Ltd)



**Wilton Street, Westminster**  
Integrated feeder pillar with signpost



**Ablemarle Street, Westminster**  
Good surface finishing around EVCP

## 4.7 Consultation

4.7.1 In order to be able to enforce highways regulations it is necessary to create a Traffic Management Order (TMO). A TMO provides the means by which consultation is carried out with statutory consultees as well as the general public. The TMOs provide details of the parking restrictions, kerbside location of the bay and other information relevant to enforcement of the bay (eg drivers must display an EV permit).

4.7.2 For on-street charging bays, once the location and layout have been determined the borough must draft and publish a TMO. The procedure is the same as that undertaken to introduce a normal parking bay. Draft TMOs are sent to consultees and are usually also advertised locally (eg in local newspapers, affixed to lamp columns). Boroughs stipulate the period within

which objections or representations can be made against the published proposals, which is usually 21 days. Once approved, the TMO is often advertised locally.

- 4.7.3 Given that charging points are a new type of technology, in addition to preparing TMOs some boroughs have also prepared consultation leaflets, which have been posted to residents, local interest groups, Ward Councillors and businesses located close to the proposed charging bays. Such leaflets might provide information which includes the following:

- Context regarding the charging point programme/technology
- An explanation of the benefits of charging points
- Reassurance to dispel perceived misconceptions (eg charging points are noisy)
- A description of the proposals (including a plan)
- Contact details for consultees to respond with comments

- 4.7.4 Different situations will require a different approach to consultation be taken. For example, if the borough is planning to displace an existing parking bay or if a charging point is to be introduced in a visually sensitive area then it may be advisable to informally consult with interested/affected parties in addition to publishing the draft TMO.

## 4.8 Enforcement

- 4.8.1 Enforcement of charging bays is undertaken by civil enforcement officers (CEO) in the same way as for parking bays. The registered owner of the vehicle may be issued with a Penalty Charge Notice (PCN) if the driver has contravened one or more of the following restrictions:

- Exceeded the permitted maximum duration of stay (eg 3 hours)
- Returned within the restricted period (eg no return on same day)
- Not displayed the required EV user permit
- Is not actively charging the vehicle
- Every part of the vehicle is not within the charging bay
- The vehicle is not classed as an electric vehicle (eg is a petrol-powered vehicle or a hybrid vehicle)



- 4.8.2 The Penalty Charge Notice contains a description of the offence and includes a contravention code which corresponds to the restrictions listed above.
- 4.8.3 Some boroughs have prepared briefing notes to help CEOs understand the procedures and parking controls that apply for EV charging bays.
- 4.8.4 While not current practice, given that most charging points record the charging duration, it is technically possible to automatically enforce the bays by turning off the electricity connection. This would be done if the vehicle overstays the time limit or by restricting access if the user returns before the specified period (eg within the same day). However, without the issue of a PCN, restricting the power supply may not provide a sufficient deterrent on its own. As the demand for charging points grows then this practice may need to be reviewed.

4.8.5 Technology has been developed to incorporate a sensor into charging bays to indicate when a non-EV user is occupying the bay or if an EV user has exceeded the maximum charging duration or is in contravention of the minimum return period. It may be possible to then automatically alert the CEO that a contravention has taken place.

#### 4.9 Charging point suppliers and energy distributor

4.9.1 As described in Chapter 3 and in Section 4.2, boroughs may choose to engage with charging point suppliers informally at any stage of the design process (including the site audit) and/or more formally through the procurement process (following approval of the TMO). A list of suppliers is provided in Appendix D.

4.9.2 Following identification of the proposed site(s) initial enquires may be made with EDF Energy to identify any potential issues with the installation of electricity and to get a quotation. Communication should be maintained with EDF throughout the design and approvals process so it is informed of progress and timescales for implementation. Contact details for EDF are shown in Appendix D.

#### 4.10 Timescales

4.10.1 Indicative timescales for the development and installation of charging point infrastructure are shown in Figure 4.9.

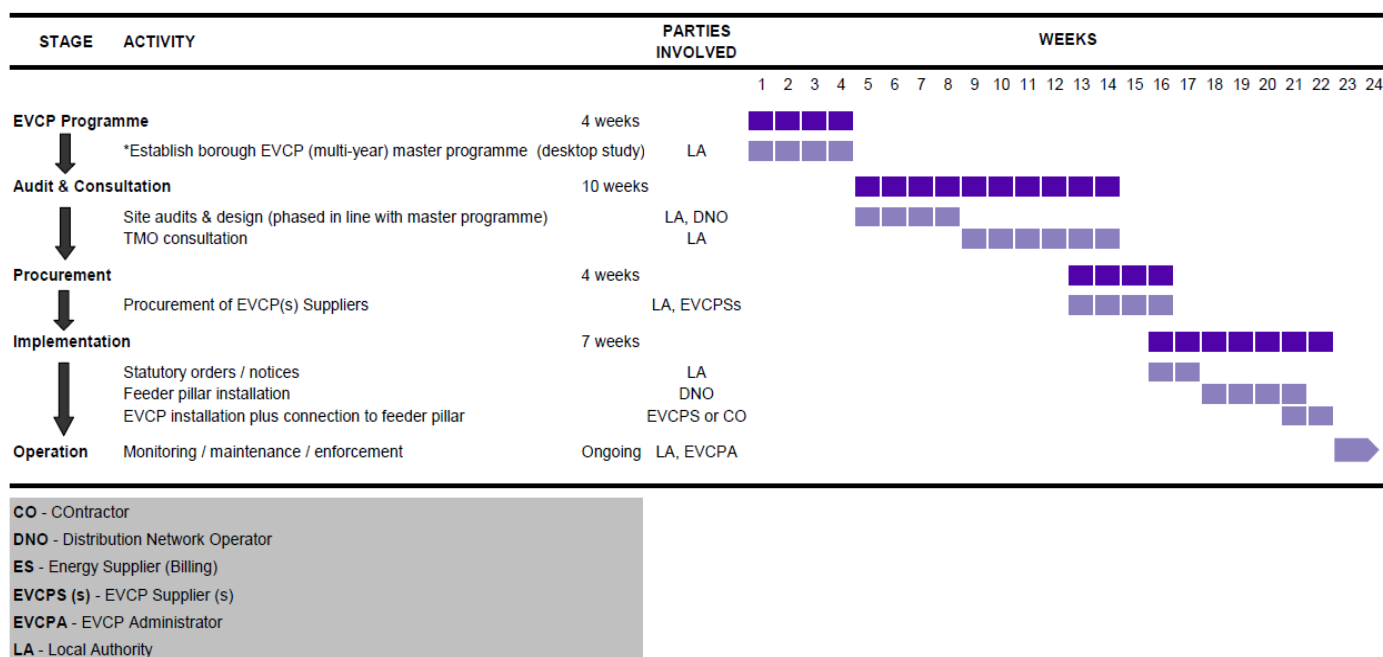

**Figure 4.9** – Indicative timescales for design and implementation of EVCP infrastructure

4.10.2 The first item in Figure 4.9 describes a process that a borough might undertake in order to establish their multi-year borough-wide implementation programme. The aim would be to define the number and type (eg on-street/off-street) and possibly also the strategy for determining where the charging points should be located (eg factors including demand).

#### Feeder pillar installation/connection to mains electricity:

Boroughs should note that while the programme indicates that the installation of feeder pillars can take up to four weeks, this process has on occasion been known to take several months. As noted in 4.9.1, this can be mitigated by engaging with the DNO early on and by maintaining close communication throughout the design and installation

4.10.3 The tasks involved in installing charging points are discussed in more detail in Chapter 5.

#### Key points:

- A desktop review should be undertaken initially to identify suitable sites
- Several factors influence a site's suitability for charging points, including: demand; visibility; road and footway space; and the potential for green hubs
- Sites audits should be undertaken to confirm a site's suitability and to determine layout details, parking controls etc
- TfL is developing a location strategy to determine locations where demand is likely to be highest for charging points
- Demand is determined by factors including: income; journey to work patterns; and trip length
- Contact should be made early on with potential EV suppliers and with the electricity distributor EDF
- Parking controls vary between boroughs. The regulatory use of road signs and markings for charging bays is currently under consultation
- Good practice principles should be applied in designing the layout of charging bays, taking note of factors such as street clutter

## Chapter 5 – Installation and maintenance

## 5. Installation and maintenance

- 5.1 Introduction
- 5.2 Installation
- 5.3 Maintenance

### 5.1 Introduction

- 5.1.1 While the installation process for charging points is relatively straightforward it is important to understand the procedures that must be followed and which parties are permitted to undertake the various tasks.

### 5.2 Installation

#### On-street/Off-street (free-standing) charging points

- 5.2.1 The steps that should be followed in installing on-street or off-street free-standing restricted access charging points are as follows:

1. Install feeder pillar
2. Provide connection from mains electricity network to feeder pillar
3. Determine location of existing services beneath proposed charging point site
4. Dig trial pit to verify there are no restrictions or obstacles, buried services or cables restricting the installation of ground anchor (see Figure 5.1)
5. Excavate hole (approx 0.3 x 0.3 x 0.6 deep) for ground anchor
6. Fix ground anchor (incorporating base plate) and cast in concrete
7. Dig trench from feeder pillar to ground anchor and lay ducting
8. Draw electrical cable through ducting from feeder pillar to ground anchor
9. Back-fill excavation and reinstate surface finish
10. Install charging point and connect to electrical cable
11. Conduct safety inspection by qualified electrical engineer

- 5.2.2 The feeder pillar needs to be located within a few metres of the charging point and six or seven 'standard charging' (13A) or three 'fast charging' (32A) charging points can be supplied from one (100A) feeder pillar. Figure 5.1 shows the groundwork components for an on-street charging point.

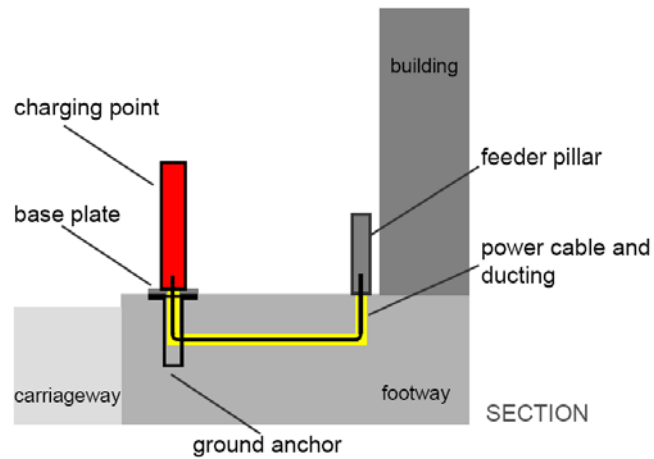

**Figure 5.1** – Groundwork components for on-street charging point

### Off-street (wall mounted) charging points

5.2.3 For external or internal (often multi-storey) car parks the installation process is easier for wall mounted charging points as a feeder pillar is not required. The installation steps are listed as follows:

- Mount charging point on wall
- Install armoured electricity cable (surface mounted or in conduit) from nearest electrical mains switch board and connect to charging point
- Conduct safety inspection by qualified electrical engineer

5.2.4 The wall mounted charging points are used in multi-storey car parks as the ground surface cannot usually be disturbed or there is limited depth to install a ground anchor. Figure 5.2 shows the electrical components for an off-street internal wall mounted charging point. The charging point should be located in a position where the charging cable is not likely to provide an obstruction to passing pedestrians.

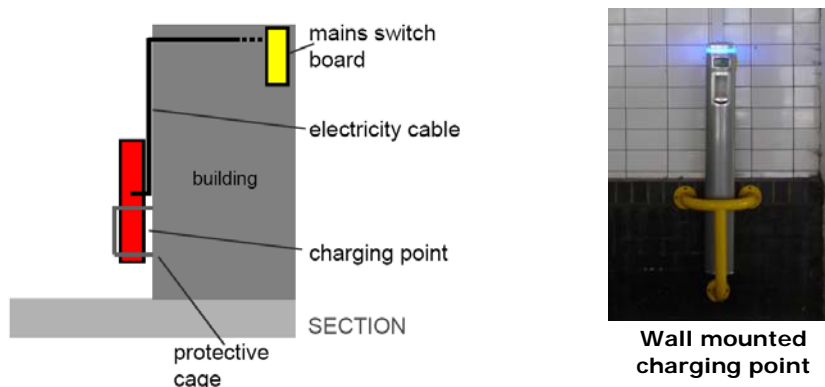

**Figure 5.2** – Section showing electrical components for off-street internal charging point

#### Q. Should I install a wall or surface mounted charging point?

This mainly depends on whether the location is on-street or in a car park, and who owns the land. Wall mounted (public) charging points are located in car parks and they do not require a feeder pillar and create less clutter. However, they must be installed in agreement with the building owner, which is more straightforward for borough-owned properties. Floor mounted charging points can be installed on-street or in car parks.

## Responsibilities for installation

5.2.5 Some elements of the installation must be carried out by the Distribution Network Operator (EDF Energy), whereas other elements are 'contestable' (ie can be completed by an approved contractor):

- Installation of feeder pillar – by Distribution Network Operator EDF Energy (assistance from contractor permissible for certain elements)
- Connection from mains network to feeder pillar – by Distribution Network Operator EDF Energy (assistance from contractor permissible for certain elements)
- Excavation for and installation of charging point – by EVCP supplier and/or borough appointed contractor
- Connection of feeder pillar to charging point (including trench work) – by EVCP supplier and/or borough appointed contractor

5.2.6 As with a typical domestic electricity supply, once the charging point has been installed the borough will need to choose an electricity supplier. The supplier will fit an electricity meter to the feeder pillar.

5.2.7 The installation steps and responsibilities are summarised in Figure 5.3.

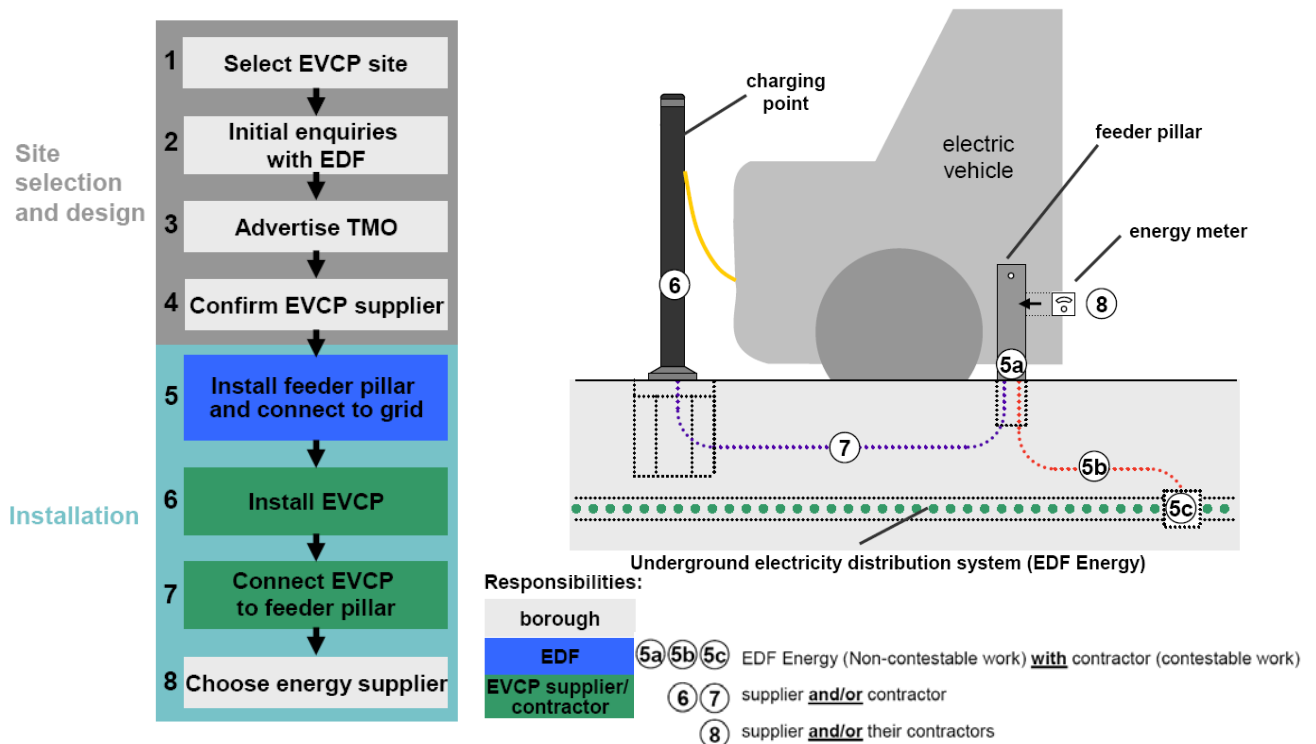

Figure 5.3 – Summary of installation steps and responsibilities

## 5.3 Maintenance

5.3.1 A borough will usually sign an annual maintenance contract with an EVCP supplier to ensure that the charging points are tested on a regular basis. The charging points in the borough of

Westminster are tested four times a year to ensure that they are functioning correctly, whereas the SWELTRAC charging points are tested twice a year. The maintenance agreements will vary depending on the levels of use that charging points are expected to experience. The design life of the metered charging points currently installed in London is estimated to be approximately 10 years.

- 5.3.2 Suppliers can minimise the risk of the charging points being defaced by using anti-graffiti paint. The charging points are designed to deflect on impact thus minimising the risk of damage to its base/foundations, which would require costly reinstallation. Enquiries should be made internally within a borough to establish whether damage to the charging points will be covered by the borough's existing public liability insurance.

**Key points:**

- Six or seven 'standard charging' (13A) or three 'fast charging' (32A) charging points can be supplied from one (100A) feeder pillar
- The installation process for wall mounted charging points is more straightforward as they do not require a feeder pillar
- Some elements of the installation process must be carried out by the electricity distributor (non-contestable work) whereas other tasks can be completed by the EVCP supplier or by a contractor (contestable work)

## Chapter 6 – Branding and publicity

## 6. Marketing, branding and publicity

- 6.1 Introduction
- 6.2 Marketing
- 6.3 Branding and publicity

### 6.1 Introduction

- 6.1.1 The charging points currently installed in London display a variety of information, some of which is common to all boroughs but much of which varies from borough to borough. The charging network is expected to grow significantly over the next few years and as such there are plans to introduce a pan-London brand during 2010.

### 6.2 Marketing

- 6.2.1 As discussed in Chapter 1, electric vehicles offer a number of environmental benefits over petrol or diesel-fuelled vehicles. So for many people, electric vehicles can provide a more sustainable alternative to their current mode of travel.
- 6.2.2 Boroughs should consider opportunities for marketing electric vehicle charging points as part of smarter travel interventions such as:

- Workplace travel plans;
- Personalised travel information;
- Development and promotion of car clubs;
- Local events/and or publications to promote sustainable travel (such as smarter travel road shows); and
- Information on council and other websites.

### 6.3 Branding and publicity

- 6.3.1 Some boroughs have branded their charging points and, as well as using their own logos, they make reference on the charging points to the sub-regional partnership through which their programmes are coordinated.
- 6.3.2 The charging points in Islington contain the environmental message 'Help us make Islington greener and cleaner' and Camden Council refers to 'Newride' on its charging points (Camden administers the Newride website through the Clear Zones Partnership).
- 6.3.3 SWELTRAC uses a common sticker for all of its charging points and this is shown below, together with examples of branding for other charging points.

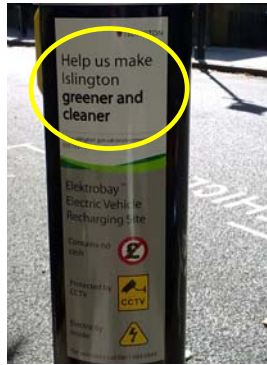

**LB Islington** – displays environmental message



**LB Wandsworth** – displays SWELTRAC logo together with a charging point symbol



**LB Islington** – charging point contains warning notices (eg 'protected by CCTV')

6.3.4 At a minimum, the charging points should contain the following information/logos:

- Borough logo
- Pan London EV logo;
- Sub-regional partnership logo (where applicable)
- EVCP supplier contact details
- Borough contact details

6.3.5 In addition, the charging points can contain additional information/logos which include:

- Borough/partnership brand/logo (eg Newride)
- Warning notices (eg danger of electricity supply, presence of CCTV)
- Statements/messages (eg 'contributes to improved environment')

6.3.6 When considering using logos and/or advertising first refer to the information in Chapter 5 on planning legislation. Boroughs should also consider copyright issues when choosing a brand for their charging points.

6.3.7 Plans are being developed for establishing a pan-London brand and logo for the charging point network. This is part of the wider plans to have a fully integrated and centrally administered network where EV users can use charging points in any borough. The introduction of the pan-London charging network is being targeted for late 2010.

6.3.8 Boroughs may still choose to promote their charging points at a local level and any borough-led marketing and promotional initiatives should continue alongside any future London-wide marketing.

#### **Private sponsorship branding**

6.3.9 Where private sponsorship is provided by EDF Energy there are a number of conditions that need to be adhered to regarding the branding and publicity of the charging points. These include using its logo and/or mentioning its name as a sponsor in any marketing and promotional material or activities. In addition, all publicity material must first be approved by EDF and it is also allowed to mention any sponsored charging points in its own publicity (without prior consent from the borough concerned).

- 6.3.10 Boroughs should be mindful that any sponsorship agreements that they enter into should not preclude future pan-London sponsorship (as referred to in 3.3.16). Further information regarding private sponsorship branding can be obtained from TfL.

**Key points:**

- Charging points should contain the TfL and borough logos, together with borough and EVCP supplier contact details
- There are plans to introduce a pan-London brand during 2010

## Chapter 7 – Administration

## 7. Administration

- 7.1 Introduction
- 7.2 Application process
- 7.3 Network administrator support
- 7.4 Future administration of pan-London network

### 7.1 Introduction

- 7.1.1 The main elements of the administration process are shown in Figure 7.1, a description of which is provided in the subsequent sections of this chapter.

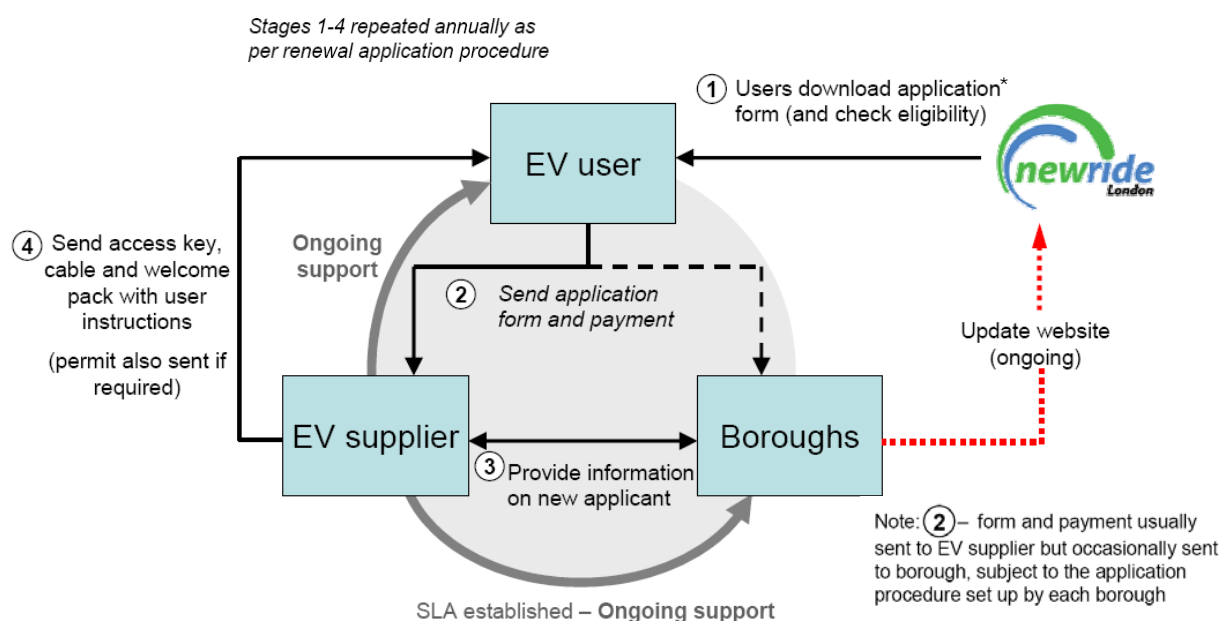

Figure 7.1 – Administration process

### 7.2 Application process

#### Stages 1 to 3 – Scheme application and subscription payment

- 7.2.1 As discussed in earlier chapters, most charging points (and all restricted access charging points) are managed through borough subscription schemes. The application forms for these schemes can be downloaded from the Newride website ([www.newride.org.uk/recharge.php](http://www.newride.org.uk/recharge.php)).
- 7.2.2 Each borough has their own application form that stipulates a number of terms and conditions to which users must agree. These include:

- Vehicles must be 100 per cent electric (or in some cases hybrid vehicles are permitted)
- Annual administration charges will apply
- Car park tariffs may apply for some charging bays
- Terms of use regarding charging points (eg must use yellow coiled cable, restricted to maximum charge period, responsibilities regarding safety)

- 7.2.3 The application forms also provide the criteria regarding eligibility for the scheme (eg must be a resident of the borough) and the necessary documents that must be provided to demonstrate evidence of eligibility (eg Council Tax bill or driving licence).
- 7.2.4 It is important to maintain a level of consistency between the application process/forms used by boroughs, particularly those which have reciprocal agreements with neighbouring/other boroughs.
- 7.2.5 For most borough subscription schemes, the completed forms and payment are sent to the EV supplier, who administers the scheme on behalf of the borough. However, for some schemes the forms and payment are sent directly to the borough. Some boroughs issue the permits and/or yellow cables themselves whereas others give this responsibility to the EV supplier. As some aspects of the application are processed by different parties it is important that a copy of the applicant's details are forwarded to the other party upon receipt.
- 7.2.6 Boroughs should consider using forms to get feedback from users on areas such as how they found out about the scheme and what they would do to improve the scheme.

#### **Stage 4 – Provision of access key, cable and user instructions**

- 7.2.7 Upon receipt of payment the following items are forwarded to the subscriber:

- Yellow coiled cable
- Two access tags
- Charging point permit (valid for one year)
- User instruction leaflet

- 7.2.8 An exception to this arrangement is for 'Smart Cars', where the car supplier provides the owner with the cable.

- 7.2.9 Part of the payment is usually refundable on return of the access tags and yellow cable.

- 7.2.10 The instruction leaflet provides information on the rules of use of the charging points, which include the following:

- Must use yellow coiled cable to charge vehicle (this helps to minimise the trip hazard)
- Charging bays can only be used while actively charging electric vehicles
- Maximum charging time as stated on charging bay signage (usually three or four hours)
- Some bays restrict users from returning to charge for a given period (eg no return during daytime hours or on the same day)
- Charging bays are for the exclusive use of those displaying borough EV permits

### 7.3 Network administrator support

#### Support to EV users

- 7.3.1 Included in the instruction pack are details of the supplier's helpline, which are usually also shown on the charging point.
- 7.3.2 The EV supplier will write to subscribers a month or so prior to the expiration of the permit, inviting them to apply for renewal. If they decide to renew the subscription then new access tags will be sent together with a new permit.

#### Support to boroughs (including Service Level Agreement)

- 7.3.3 As discussed in Chapter 3, boroughs pay a monthly and annual fee to the EVCP supplier for administering the scheme, which involves: issuing the cable and access tags to the user, processing initial/annual subscription payments, operating a user helpline, maintaining the charging points and providing regular information to the borough on charging point usage.
- 7.3.4 The arrangement between the two parties is set out in a Service Level Agreement (SLA). An SLA is a contract between the provider of a service (the EVCP supplier) and the user of that service (the borough). The SLA defines the minimum performance measures at or above which the service delivered is considered acceptable.
- 7.3.5 The main elements that should be covered by an SLA include:

- Responsibilities for dealing with subscription applications
- Responsibilities/details for processing payments
- Process for issuing welcome packs (and what they contain, eg access keys)
- Details of process for subscription renewal/reminders
- Details of user database management
- Details of user support provided (including helpline), and maximum response times for enquiries
- Charging point maintenance procedures
- Provision of charging point usage reports to the borough

- 7.3.6 The frequency of provision of the usage reports varies between boroughs, from monthly to quarterly reporting. The reports are usually provided in spreadsheet format.
- 7.3.7 An SLA pro-forma is shown in Appendix B. Boroughs should liaise with the EVCP supplier who will be administering the scheme to complete the pro-forma to identify the minimum level of service.

### 7.4 Future administration of pan-London network

- 7.4.1 As part of the plan to introduce a pan-London charging point network in late 2010, proposals are being developed for the establishment of a centralised administration system.

7.4.2 A pan-London charging network will bring together the publically accessible charging points in London, meaning the user will only need to register once, paying an annual fee, to be able to access a uniformly consistent charging service across London. The charging points will be accessible using a common tag or card and will be free at the point of use to draw on the electricity supply. The charging points will all share a common branding and information on their location and availability can be viewed from one website.

7.4.3 In summary, as noted in *London's EV Infrastructure Strategy*, it is envisioned that the pan-London scheme will have:

- Inter-operable tags or cards accepted by all scheme charging points
- Common branding for all scheme charging points, with their location and availability viewable from one website
- Standard charging point connectors
- A call centre for help and advice and to report any issues

7.4.4 The benefits of operating a single London-wide administration system are likely to include:

- Standardisation of application requirements/procedures
- Online registration and payment possible
- Rationalisation of user and borough administration charges
- Medium for disseminating good practice
- Means of identifying charging point location and availability
- Means of monitoring charging point usage (allowing for flexible charging tariffs)
- Centrally administered user support/helpline
- Automatic fault monitoring of charging points
- Remote access/operation of charging point
- Remote authentication (allowing access by non-registered users, for example, by using text-based payments)
- Substantial cost savings in administration (likely to result in lower costs for users and boroughs)

**Key points:**

- The arrangements regarding support provided to boroughs from EVCP suppliers are set out in Service Level Agreements
- An EVCP supplier is currently responsible for the administration of the borough's EVCP networks
- EVCP suppliers provide boroughs with regular reports on charging point usage
- As part of the planned pan-London charging point network proposals are being developed for a centralised administration system

## Appendix A – Design checklist

## Appendix A – Design checklist

Scheme development stage	Comments	Guide reference	Completed?
<b>Location of charging points</b>			
Identify locations for charging points	Undertake desktop review to determine where to locate charging points – consider factors which include demand, visibility/ accessibility, road space, footway space and potential to create Green Hubs.	4.2.1-4.2.6	
<i>As part of its plans to introduce a pan-London charging point network, TfL is developing a charging point location strategy. Work completed to date is summarised in London's EV Infrastructure Strategy.</i>			
Confirm suitability of locations	Undertake site audits for the locations identified as part of the desktop review. The audit should be used to make observations related to factors which include: land ownership, footfall, current parking controls and location of street furniture.	4.2.7-4.2.8	
<i>Boroughs may choose to engage with charging point suppliers informally at any stage of the design process (including the site audit) and/or more formally through the procurement process.</i>			
<i>In order to mitigate the likelihood of delays related to energy connections, contact should be sought early on with the energy distributor EDF – ideally as soon as the charging point location has been identified.</i>			
<b>Planning legislation</b>			
Check whether a planning application is required	Consider whether a planning application is required for the installation of the charging point or for the use of signage or advertisements.	4.3	
<i>In November 2009, the Department for Communities and Local Government published a consultation document that proposed policy options to clarify the planning requirements.</i>			
<b>Parking controls</b>			
Type of restrictions	Different types of controls will be suitable in different circumstances, eg busy high streets may require more stringent restrictions. Consider the most appropriate solution for the particular location and whether parking charges should apply.	4.4.1-4.4.4	
Parking permits	Consider whether a fee should be charged for issuing a permit to an EV driver, whether this should be open to those that work as well as those that live in the borough, and (in consultation with other boroughs) whether this should entitle them to charge in other (possibly neighbouring) boroughs as well.	4.4.5-4.4.9	
Parking concessions	Consider whether EV users should be given parking concessions for non-charging bays (eg normal pay and display bays or car parks).	4.4.7	
<i>While a standard sign face layout has been adopted by London boroughs that operate EVCPs, type approval is currently required from the DfT. The DfT published a consultation document in September 2009 proposing that signs similar to these become regulatory.</i>			
<i>It is expected that in the near future all EVCP subscribers will be able to access charging points across all London boroughs. At present subscribers can only access charging points within their local borough or, in some cases, in neighbouring boroughs (with which they have a common access agreement).</i>			

<b>Type of charging point</b>			
Restricted access or open access charging point?	Open access charging points can be used by any EV owner, however it will not be possible to integrate them into the pan-London network. Restricted access points are for the use of subscribers only. Restricted access EVCPs offer more to the user and administrator in terms of current/future functionality and fit into the model of achieving a London-wide integrated, consistent and intelligent charging point network.	2.5.11	
Internal or external feeder pillar?	Consider which type of feeder pillar to use. The factors that impact on the choice/suitability of the feeder pillar type include: impact on street clutter, footway space and whether they are on-street or off-street.	4.5.10-4.5.11	
Wall or surface mounted charging point?	Consider which type of charging points to use. This mainly depends on whether the location is on-street or in a car park, and who owns the land. Wall mounted (public) charging points are located in car parks and they do not require a feeder pillar and create less clutter.	5.2.4	
<i>The aspiration is that in the near future all charging points in London will be able to communicate information remotely. This means that some of the existing charging points will need to be retro-fitted with the new technology.</i>			
<i>TfL is in the process of defining the minimum requirements for the functionality of charging points that will form the pan-London network. Two of the requirements will be that the charging points must be able to communicate remotely and that there must be a means of monitoring usage for individual users.</i>			
<b>Layout details</b>			
Good practice principles	Follow established good practice principles for designing the layout of on-street charging bays, which include: avoiding street clutter, ensuring sufficient footway width and, where possible, locating sign plate on existing post/lamp column or on wall.  Although off-street bays are not on the public highway and therefore the signs and road markings are non-regulatory, ensure that there is a degree of consistency in the layout, colour and dimensions of the signs and markings used across the borough. This will to assist EV drivers in locating the charging bays and in interpreting the parking restrictions.	4.5.3  4.5.5-4.5.6	
Impact on streetscape	Consider the visual impact that the charging point will have on its surroundings, including factors such as consistency with other street furniture. This should be informed by borough and TfL streetscape guidance.	4.6.1-4.6.3	
<b>Consultation</b>			
Formal and informal consultation	Different situations will require a different approach to be taken to consultation. It might be advisable to informally consult with interested/affected parties in addition to publishing the draft TMO.	4.7.1-4.7.4	
<b>Enforcement</b>			
Briefing notes	Consider whether briefing notes should be prepared to help CEOs understand the procedures and parking controls that apply for charging bays.	4.8.3	
<b>Branding and publicity</b>			
Charging point information/logos	Ensure that the charging points contain the minimum recommended information/logos.	6.2.1-6.2.9	

*Plans are being developed for establishing a pan-London brand and logo for the charging point network. This accords with the wider aspiration to have a fully integrated and centrally administered network where EV users can use charging points in any borough.*

**Administration**

Service Level Agreement	Enter into Service Level Agreement with the chosen EVCP supplier/s for administration of the borough's EVCP network.	7.3.3-7.3.5	
-------------------------	--	-------------	--

*As part of the plan to introduce a pan-London charging point network proposals are being developed for the establishment of a centralised administration system. Such a system will provide the means by which information is communicated on charging point location, availability, usage, user support, fault reporting and good practice.*

Appendix B – Service Level Agreement pro-forma

# Service Level Agreement pro-forma

**\*\*Review and change/remove red text as appropriate\*\***

## Service Level Agreement for *EVCP administrator* to administer the electric vehicle recharging scheme for *London borough*

This agreement sets out the services that will be provided by *EVCP administrator* in the administration of *London borough's* electric vehicle recharging scheme.

Agreement start date:

Agreement end date:

Services to be provided by <i>EVCP administrator</i>	Description/notes
<b>1. Applications:</b>	
Managing the application process	User application forms can be downloaded from <i>website.com</i> website and sent to <i>EVCP administrator</i> . Supporting documents required must be stipulated on the application form. Customers will also be able to call or email <i>the EVCP administrator</i> directly on ##### or <i>name@email.com</i> to request application forms. <u>Forms to be sent out within <i>x days</i> of request.</u>
<b>2. Payment processing:</b>	
Processing payments from new applicants	<i>EVCP administrator</i> will accept and process <i>cheques/credit cards/debit cards/postal orders</i> . Customers will be charged <i>Exx.xx</i> plus VAT, for which users will receive their yellow cable, two access keys, user guide <i>and permit</i> . A full breakdown of the costs covered by this payment is given below:  <i>Annual fee (Exx.xx), yellow cable (Exx.xx), two access keys and user guide (Exx.xx), permit (Exx.xx), annual fuel charge (Exx.xx), postage and packing (Exx.xx), credit card surcharges (Exx.xx).</i>  All payments must be made to the <i>London borough/EVCP administrator</i> and must contain the following reference: <i>reference number/cost centre/account code</i> .
<b>3. Welcome pack:</b>	
Send out a Welcome Pack to new members	The Welcome Pack will contain the yellow cable (with the correct socket for their EV), two access keys, a user guide <i>and a permit</i> . <i>The EVCP administrator</i> will procure and supply the yellow cable on behalf of <i>London borough</i> . <u>Welcome Packs will be sent out within <i>x days</i> of <i>application form/payment</i> receipt.</u>  Note: a quote will be provided for any non-standard plugs required by an applicant, with an additional charge for supply to the customer as

applicable.

Programme access tags to allow *12 months* access to EVCPs in *London borough(s)*

At the end of *12 months* the keys will time-out to prevent further access. If a customer wishes to sign up for a second year they must renew their membership *and permit*, and pay for a renewal annual subscription.

#### 4. Subscription renewals:

Send members a reminder message *one month* before their subscription (ie access keys) expires

The reminder message will advise users to contact *EVCP administrator* for renewal forms. The message will be sent via email (with renewal forms attached), text or on a postcard. *If there is no response within x days a follow-up letter or postcard will be sent* enclosing a renewal application form.

Process renewal application forms and send out a Renewal Welcome Pack

The Renewal Welcome Pack will contain two personalised access keys, a user guide, a pre-paid postal bag and a renewal note. The renewal note will advise the user to have their cable tested by the *cable provider* or a qualified electrician. The pre-paid postal bag is for return of the old keys. *Renewal Welcome Packs will be sent out within x days of application form/payment receipt.*

Customers will be charged *£xx.xx* plus VAT at the standard rate. A full breakdown of the costs covered by this payment is given below:

*Renewal annual fee (£xx.xx), two access keys, user guide and renewal note (£xx.xx), permit (£xx.xx), annual fuel charge (£xx.xx), postage and packing (£xx.xx), pre-paid postal bag (£xx.xx), credit card surcharges (£xx.xx).*

All payments must be made to the *London borough/EVCP administrator* and must have the following reference: *reference number/cost centre/account code.*

#### 5. User database:

Maintain and update a database of all members

Maintain an up to date database with members' details. This data will remain the property of *London borough* and all data shall remain confidential and shall not be passed on to third parties.

#### 6. User support:

Operate a user helpline

Answer all customer queries relating to administration, payment and faults via phone or email. The helpline number: *XXXX XXX XXXX* to be operated during the hours *XXXX – XXXX* during *weekdays*. A telephone automatic answering machine will operate outside of these hours. Emails and phone messages to be returned within *x days*.

## 7. Equipment replacement:

*EVCP administrator* to oversee replacement of lost/stolen keys/cables

Customers will be charged *£xx.xx* + VAT to replace yellow cable and *£xx.xx* + VAT to replace a lost access key. Payments to be processed and replacements supplied by *EVCP administrator*. The replacement cable/key will be sent out within *x days* following request.

## 8. Reporting:

Provide *London borough* with reports on number of users and usage statistics including performance data from the EVCPs

Reports on number of users and welcome packs sent out will be supplied to *London borough* on a *monthly* basis.

Provide *London borough* with a detailed summary of usage statistics and performance data for each charging point at *x monthly* intervals.

The reports will include:

- consumption of electricity per EVCP and per user
- number of overstays per EVCP and per user
- carbon reduction per mile over conventional vehicle of similar size
- *any other additional information required*

The usage data will remain the property of *London borough* and all data shall remain confidential and shall not be passed on to third parties.

*London borough* will pay *EVCP administrator* to administer this scheme the sum of *£xxx.xx* per *month/year* irrespective of the number of users taking part in the scheme.

*EVCP administrator* contact details:

Name:

Address:

Email:

Telephone number:

Signed:

Position:

Date:

## Appendix C – References

## Appendix C - References

City of Westminster (2006), *Installation of Two on-Street Recharging Points for Electric Vehicles*  
[www.westminster.gov.uk/services/environment/pollution/airpollution/ecomark/installation/](http://www.westminster.gov.uk/services/environment/pollution/airpollution/ecomark/installation/)

City of Westminster (2008), *Understanding existing electric vehicle charging infrastructure, vehicles available on the market and user behaviour and profiles*

Department for Communities and Local Government (2009a), *Review for permitted development for charging points for electric cars*  
[www.communities.gov.uk/publications/planningandbuilding/electriccarsreview](http://www.communities.gov.uk/publications/planningandbuilding/electriccarsreview)

Department for Communities and Local Government (2009b), *Permitted development rights for small-scale renewable and low carbon energy technologies, and electric vehicle charging infrastructure*  
[www.communities.gov.uk/archived/publications/planningandbuilding/microgenelectriccars](http://www.communities.gov.uk/archived/publications/planningandbuilding/microgenelectriccars)

Department for Transport (2007), *Manual for Streets*  
[www.dft.gov.uk/pgr/sustainable/manforstreets/](http://www.dft.gov.uk/pgr/sustainable/manforstreets/)

Department for Transport (2008a), *Investigation into the Scope for the Transport Sector to Switch to Electric Vehicles and Plug-in Hybrid Vehicles*  
[www.dft.gov.uk/pgr/scienceresearch/technology/lowcarbonelecvehicles/](http://www.dft.gov.uk/pgr/scienceresearch/technology/lowcarbonelecvehicles/)

Department for Transport (2008b), *LTN 1/08 Traffic Management and Streetscape*  
[www.dft.gov.uk/pgr/roads/tpm/ltnotes/ltn108.pdf](http://www.dft.gov.uk/pgr/roads/tpm/ltnotes/ltn108.pdf)

Department for Transport (2009a), *CENEX Alternative Fuels Infrastructure Grants Programme Guidance*  
[www.cenex.co.uk/](http://www.cenex.co.uk/)

Department for Transport (2009b), Consultation document: *Traffic Signs (Amendment) Regulations and General Directions (TSRGD) 2010*  
[www.dft.gov.uk/consultations/closed/trafficsignsamendmentregs/](http://www.dft.gov.uk/consultations/closed/trafficsignsamendmentregs/)

Department for Transport (2009c), *Low Carbon and Electric Vehicles*  
[www.dft.gov.uk/pgr/scienceresearch/technology/lowcarbonelecvehicles/](http://www.dft.gov.uk/pgr/scienceresearch/technology/lowcarbonelecvehicles/)

Department for Transport (2009d), *Ultra-low Carbon Cars: Next steps on delivering the £250 million consumer incentive programme for EVs and PHEVs*  
[www.dft.gov.uk/pgr/scienceresearch/technology/lowcarbonelecvehicles/](http://www.dft.gov.uk/pgr/scienceresearch/technology/lowcarbonelecvehicles/)

EDF Energy (2009), *About EDF Energy and Connections – Your Choice*  
[www.edfenergy.com/products-services/networks/pdf/connections\\_your\\_choice.pdf](http://www.edfenergy.com/products-services/networks/pdf/connections_your_choice.pdf)

Mayor of London (2009a), *An Electric Vehicle Delivery Plan for London*  
[www.london.gov.uk/who-runs-london/mayor/publications/transport-and-streets/electric-vehicle-delivery-plan-london](http://www.london.gov.uk/who-runs-london/mayor/publications/transport-and-streets/electric-vehicle-delivery-plan-london)

Mayor of London (2009b), *Mayor's Transport Strategy – Public Draft*  
[http://mts.tfl.gov.uk/docs/MTS09\\_Complete.pdf](http://mts.tfl.gov.uk/docs/MTS09_Complete.pdf)

Mayor of London (2009c), *London's Electric Vehicle Infrastructure Strategy - draft for consultation*  
[www.london.gov.uk/electricvehicles/docs/GLA\\_ELI\\_Strategy\\_09\\_V05.pdf](http://www.london.gov.uk/electricvehicles/docs/GLA_ELI_Strategy_09_V05.pdf)

Statutory Instrument 2002 No. 3113, *The Traffic Signs Regulations and General Directions 2002*

SWELTRAC (2007), *Provision of Electric Vehicle Recharging Points across the SWELTRAC Region – Feasibility Study*

Transport for London (2009), *Streetscape Guidance*  
[www.tfl.gov.uk/businessandpartners/publications/4858.aspx](http://www.tfl.gov.uk/businessandpartners/publications/4858.aspx)

## **Websites:**

EV Network UK  
[www.ev-network.org.uk](http://www.ev-network.org.uk)

Department for Transport – Signage  
[www.dft.gov.uk/pgr/roads/tss/](http://www.dft.gov.uk/pgr/roads/tss/)

London Electric Vehicles (Greater London Authority)  
[www.london.gov.uk/electricvehicles/contacts/](http://www.london.gov.uk/electricvehicles/contacts/)

London European Partnership for Transport  
[www.lept-eu.org/](http://www.lept-eu.org/)

Newride London  
[www.newride.org.uk/](http://www.newride.org.uk/)

TfL extranet – information on electric vehicle charging points  
<http://boroughs.tfl.gov.uk/1054.aspx>

## Appendix D – Important contacts

## Appendix D – Important contacts

### Transport for London

For enquiries regarding:

#### LIP funding and scheme development/progress:

Programme Manager  
Surface Transport (Better Routes and Places)

Omoniyi Giwa

T: 0203 054 4910 (Internal: 84910) E: [omonyigiwa@tfl.gov.uk](mailto:omonyigiwa@tfl.gov.uk)

Transport for London, 9th Floor (9G2), Palestra,  
197 Blackfriars Road, Southwark, London, SE1 8NJ

#### Signage and logos:

Logos and the New Johnston font can be requested online from the extranet  
<https://extranet.tfl.gov.uk/boroughs/glp/bsps/signage-logos.aspx>

TfL Investment Programme Signage Manager

Rachel Comerford

T: 020 7126 4499 07702 669738 E: [rachelcomerford@tfl.gov.uk](mailto:rachelcomerford@tfl.gov.uk)

#### Streetscape:

TfL Streetscape Officer

E: [StreetscapeGuidance@tfl.gov.uk](mailto:StreetscapeGuidance@tfl.gov.uk)

Transport for London, Palestra,  
197 Blackfriars Road, London, SE1 8NJ

#### Development of policy on pan-London network for charging points:

Steve Smith

T: 020 3054 2041 E: [Steve.Smith@tfl.gov.uk](mailto:Steve.Smith@tfl.gov.uk)

Mark Poulton

T: 020 3054 1583 E: [markpoulton@tfl.gov.uk](mailto:markpoulton@tfl.gov.uk)

## Greater London Authority

For enquiries regarding:

### **London's Electric Vehicle Infrastructure Strategy:**

E: [ev@london.gov.uk](mailto:ev@london.gov.uk)

[www.london.gov.uk/electricvehicles/docs/GLA\\_ELI\\_Strategy\\_09\\_V05.pdf](http://www.london.gov.uk/electricvehicles/docs/GLA_ELI_Strategy_09_V05.pdf)

## Department for Transport

For enquiries regarding:

### **Type approval for signage:**

Traffic Signs Policy Branch

E: [traffic.signs@dft.gsi.gov.uk](mailto:traffic.signs@dft.gsi.gov.uk)

Helpdesk: 0300 330 3000 (08.30 to 17.30, Monday to Friday)

[www.dft.gov.uk/pgr/roads/tss/](http://www.dft.gov.uk/pgr/roads/tss/)

## Funding

For enquiries regarding:

### **European Union funding:**

London European Partnership for Transport (LEPT)

Paul Curtis

T: 020 7934 9536 E: [Paul.Curtis@lept-eu.org](mailto:Paul.Curtis@lept-eu.org)

[www.lept-eu.org](http://www.lept-eu.org)

## Administration

For enquiries regarding:

### **Newride**

[www.newride.org.uk/](http://www.newride.org.uk/)

Clear Zones Partnership,  
London Borough of Camden, Argyle Street,  
London, WC1H 8EQ

Tina Pancha (LB Camden)

T: 020 7974 5896 E: [Tina.Pancha@camden.gov.uk](mailto:Tina.Pancha@camden.gov.uk)

## Charging point suppliers

Elektromotive – ‘Elektrobay’

[www.elektromotive.com](http://www.elektromotive.com)

The Sussex Innovation Centre, Science Park Square,  
Falmer, Brighton, East Sussex, BN1 9SB

T: 01273 704775 E: [info@elektromotive.com](mailto:info@elektromotive.com)

**Infracharge** – ‘POD Point’

[www.infracharge.com](http://www.infracharge.com) [www.pod-point.com](http://www.pod-point.com)

ECC Infracharge Ltd, Mayfair Car Centre, Park Lane,  
London, W1K 7AN

T: 0845 519 1995 020 7402 4334 E: [enquiries@pod-point.com](mailto:enquiries@pod-point.com),  
[info@infracharge.com](mailto:info@infracharge.com)

**365 Energy Group** – ‘ChargePoint’

[www.365-energy.com](http://www.365-energy.com)

365 Energy Group, Fasanenstr. 29, 10719 Berlin, Germany

T: +49 30 887 745230 E: [leah.odwyer@365-energy.com](mailto:leah.odwyer@365-energy.com)

## Energy Distribution Network Operator

**EDF Energy Ltd**

[www.edfenergy.com/](http://www.edfenergy.com/)

EDF Energy Networks, Bircholt Road, Parkwood, Maidstone, Kent,  
ME15 9XH

EDF general enquiries for connections

T: 0845 234 0040 E: [connections@edfenergy.com](mailto:connections@edfenergy.com)

## Appendix E – EVCP Partnership Working Group

## Appendix E - EVCP Partnership Working Group

This group has been operating since January 2009 and is made up of borough officers responsible for the implementation of electric vehicle infrastructure in London's 33 boroughs. The aim of the group is to address operational issues, share best practice and develop plans to meet the Mayor's EV Strategy.

The Group meets every two months and typical agenda items include: bulk procurement; external funding; new technology and suppliers; branding; EU initiatives; pan-London strategy and administration.

### Contact information

For further information, please contact:

**Stella Lam**

Assistant Programme Manager  
Better Routes and Places  
Transport for London  
9th Floor (9G2), Palestra, 197 Blackfriars Road,  
Southwark, London, SE1 8NJ

T: 0203 058 4944

E: [StellaLam01@tfl.co.uk](mailto:StellaLam01@tfl.co.uk)



## Glossary

<b>3-pin plug</b>	UK domestic plug
<b>Blue commando</b>	Industrial type of electric plug that can be safely used outside without a protective cover
<b>CEO</b>	Civil enforcement officers
<b>DNO</b>	Distribution Network Operator – responsible for distributing energy and maintaining the electrical supply system
<b>EEC</b>	European Economic Community
<b>Electricity supplier</b>	Electricity company to whom the user pays their electricity bill
<b>EV</b>	Electric vehicle
<b>EVCP</b>	Electric vehicle charging point
<b>EVCPPWG</b>	Electric Vehicle Charging Point Partnership Working Group
<b>EVDP</b>	Electric Vehicle Delivery Plan for London
<b>Feeder pillar</b>	Controls electricity outputs to devices, including lighting, signalling and charging points
<b>Fast charging</b>	Method of charging vehicles using higher amps and volts resulting in a quicker transfer of electricity to speed up the charging process
<b>Gateway</b>	Charging point through which other local charging points communicate via LAN connection. Gateway communicates via GPRS to a server
<b>GLA</b>	Greater London Authority
<b>GPRS</b>	General Packet Radio Service
<b>kW</b>	kilo Watt
<b>LAN</b>	Local Area Network connection – information from charging points communicated remotely along the LAN connection to the gateway charging point
<b>LIP</b>	Local Implementation Plan
<b>Open access</b>	Charging point which all users can access (ie not restricted access)
<b>PCN</b>	Penalty Charge Notice
<b>PHEV</b>	Plug-in hybrid electric vehicle
<b>Restricted access</b>	Charging point usage restricted to subscribers
<b>RFID</b>	Radio Frequency Identification – a system that transmits the identity (in the form of a unique serial number) of an object or person wirelessly using radio waves.
<b>SLA</b>	Service Level Agreement
<b>Standard charging</b>	Most popular current charging system using 13A current
<b>TEC</b>	London Councils' Transport and Environment Committee
<b>TfL</b>	Transport for London
<b>TMO</b>	Traffic Management Order